

### General features for MPa Series (AGM) battery

- \* Stable quality & high reliability.
- \* Unique construction and sealing technique guarantees.
- \* Design life 5years in float service; Long service life ,float or cyclic, which is shown in the specification sheet.
- \* Maintenance-free operation. UL-recognized component.
- \* Heavy duty grids: The heavy-duty lead calcium-alloy grids ,provide an extra margin of performance and service life in float & cyclic.
- \* Case and cover are available in both standard and flame retardant ABS.
- \* Low self discharge; low pressure venting system.



**Maxton Power Tech Co., Ltd**  
www.maxtonpower.com  
info@maxtonpower.com

## MP12-0.8 (12V0.8Ah)

### Specifications

Nominal Voltage		12V
Rated capacity (20 hour rate)		0.8Ah
Dimensions (±1mm)	Total Height	62mm (2.44 inches)
	Height	62mm (2.44 inches)
	Length	96mm (3.78 inches)
	Width	25mm (0.98 inches)
Weight Approx (±3%)		0.33Kg (0.72 lbs)

### Battery picture and construction



#### Battery Construction

Component	Positive plate	Negative plate	Container	Cover
Raw material	Lead dioxide	Lead	ABS	ABS
Component	Electrolyte	Separator	Safety valve	Terminal
Raw material	Dilute sulfuric acid	Fiberglass	Rubber	Wire+connector

### Outer dimension and terminal

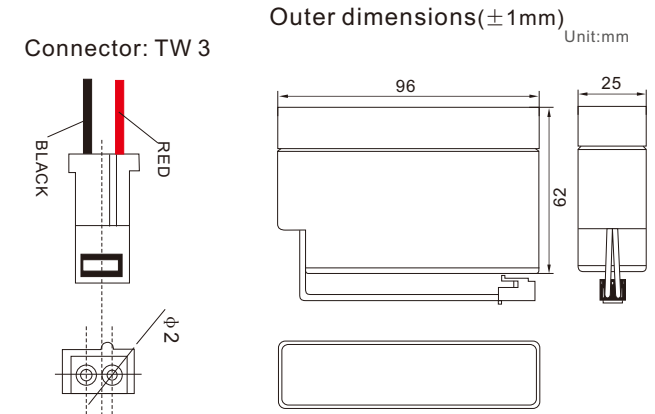

### Characteristics

Capacity 25°C(77°F)	20 hour rate(0.04 A,10.5V) 10 hour rate(0.07A,10.5V) 5 hour rate(0.13A,10.5V) 1 hour rate(0.48A,9.6V)	0.8Ah 0.7Ah 0.65Ah 0.48 Ah
Internal Resistance	Full charged battery at 25°C(77°F)	Approx 130 mΩ
Capacity affected by Temperature (20hour rate)	40°C (104°F) 25°C (77°F) 0°C (32°F) -15°C (5°F)	102% 100% 85% 65%
Remaining capacity Self-Discharge At 25°C(77°F)	Capacity after 3 month storage Capacity after 6 month storage Capacity after 12 month storage	91% 82% 64%
Terminal Type (wire+connector)	TW13	
Max. Discharge current 25°C(77°F)	12A (5Seconds)	
Nominal operating temperature	25°C ±5°C(77°F ±9°F)	
Operating Temperature Range	Discharge -15°C ~50°C (5°F ~122°F) Charge -10°C ~50°C (14°F ~122°F) Storage -20°C ~50°C (-4°F ~122°F)	
Charge methods (constant Voltage) At 25°C(77°F)	Cycle use	Initial Charging Current less than 0.24 A Voltage 14.10-14.40V Temperature compensation:-30mV/°C
	Standby use	Voltage 13.50-13.80V Temperature compensation:-18mV/°C

### Constant current discharge (25°C , 77 °F)

### Constant power discharge (25°C , 77 °F)

Unit:A

Unit:watts

Time		5min	10min	15min	30min	1h	2h	3h	4h	5h	8h	10h	20h
9.60V	A	2.70	1.77	1.31	0.86	0.45	0.26	0.19	0.16	0.13	0.09	0.07	0.04
	W	31.84	20.00	15.13	9.16	5.19	3.04	2.23	1.79	1.52	1.00	0.82	0.45
10.20V	A	2.48	1.69	1.21	0.82	0.42	0.25	0.19	0.15	0.13	0.09	0.07	0.04
	W	29.97	18.94	14.22	9.09	4.88	2.92	2.17	1.74	1.49	0.99	0.81	0.44
10.50V	A	2.25	1.58	1.13	0.79	0.41	0.25	0.18	0.14	0.13	0.08	0.07	0.04
	W	28.94	18.38	13.59	9.00	4.73	2.86	2.13	1.65	1.48	0.98	0.80	0.43
10.80V	A	2.17	1.51	1.05	0.77	0.40	0.24	0.18	0.14	0.12	0.08	0.07	0.04
	W	25.37	17.81	13.09	8.97	4.59	2.80	2.11	1.63	1.42	0.94	0.78	0.43
11.10V	A	2.00	1.43	0.98	0.75	0.38	0.23	0.17	0.14	0.12	0.08	0.07	0.04
	W	24.53	17.22	12.47	8.91	4.53	2.78	2.05	1.63	1.39	0.91	0.77	0.42

(Above characteristics data are average values obtained within three charge/discharge cycles,not the minimum values.)

# VRLA Battery (AGM technology) Maintenance-free Sealed Lead Acid Rechargeable Battery

**Discharge characteristics (25°C, 77°F)**

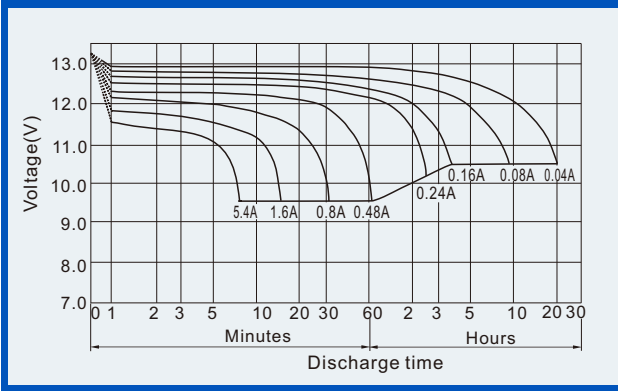

**Charge characteristics (25°C, 77°F)**

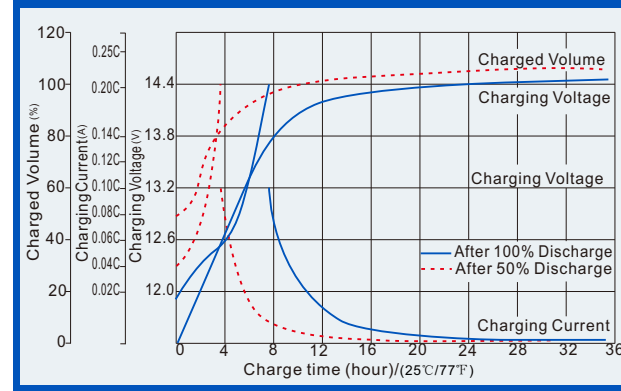

**Life characteristics of Cyclic Use (25°C, 77°F)**

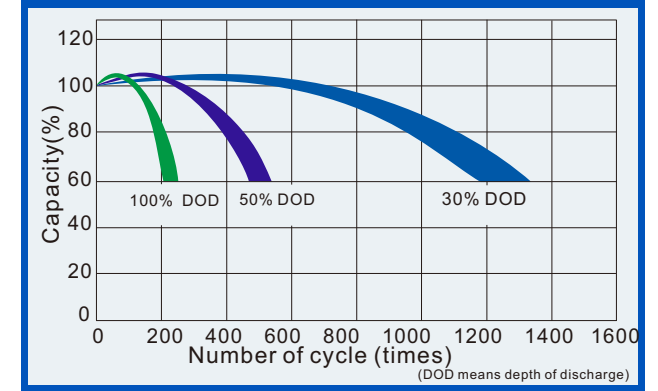

**Effect of Temperature on capacity**

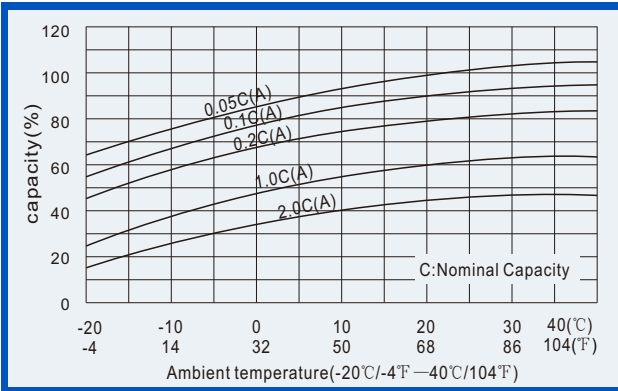

**Self-discharge characteristics**

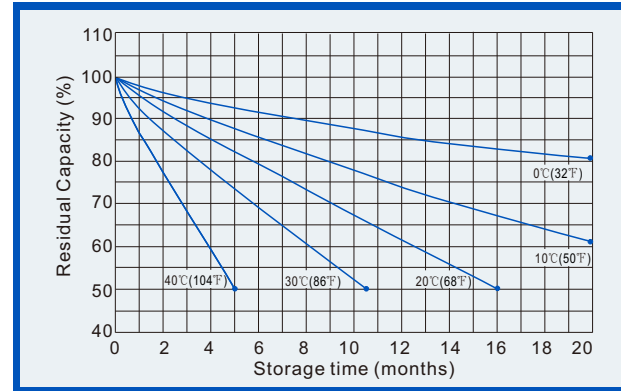

**Life Characteristics of standby use (25°C, 77°F)**

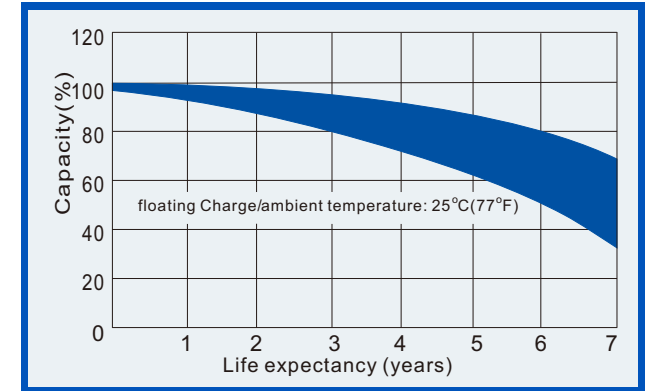

**Relationships for open voltage and remained capacity (for reference)**

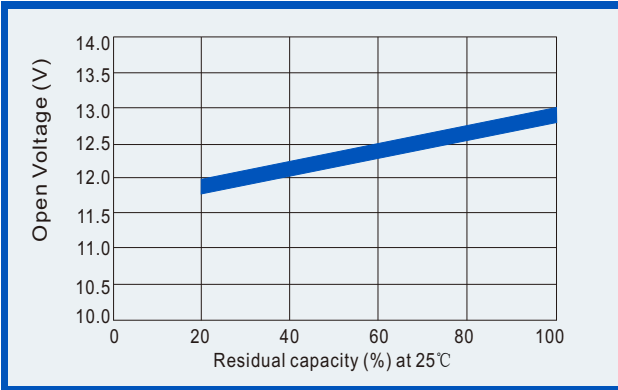

**Relationship for charging voltage and temperature**

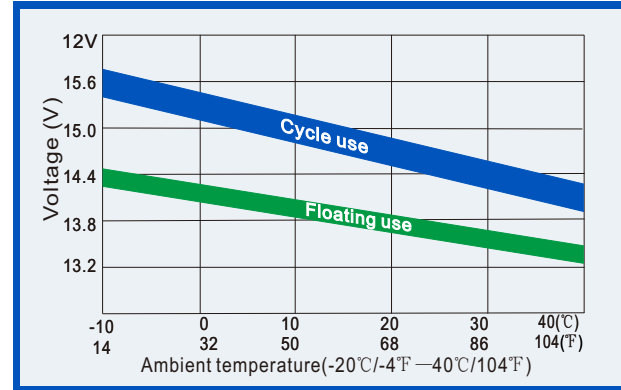

**Temperature effects on floating life**

