

General features for MPa Series (AGM) battery

- * Stable quality & high reliability.
- * Unique construction and sealing technique guarantees.
- * Design life 5years in float service; Long service life ,float or cyclic, which is shown in the specification sheet.
- * Maintenance-free operation. UL-recognized component.
- * Heavy duty grids: The heavy-duty lead calcium-alloy grids ,provide an extra margin of performance and service life in float & cyclic.
- * Case and cover are available in both standard and flame retardant ABS.
- * Low self discharge; low pressure venting system.



Maxton Power Tech Co., Ltd
www.maxtonpower.com
info@maxtonpower.com

MP12-22 (12V22Ah)

Specifications

Nominal Voltage		12V
Rated capacity (20 hour rate)		20Ah
Dimensions (±2mm)	Total Height	167 mm (6.57 inches)
	Height	167 mm (6.57 inches)
	Length	181 mm (7.13 inches)
	Width	77 mm (3.03 inches)
Weight Approx (±3%)		5.80 Kg (12.8 lbs)

Battery picture and construction



Battery Construction

Component	Positive plate	Negative plate	Container	Cover
Raw material	Lead dioxide	Lead	ABS	ABS
Component	Electrolyte	Separator	Safety valve	Terminal
Raw material	Dilute sulfuric acid	Fiberglass	Rubber	Copper

Outer dimension and terminal

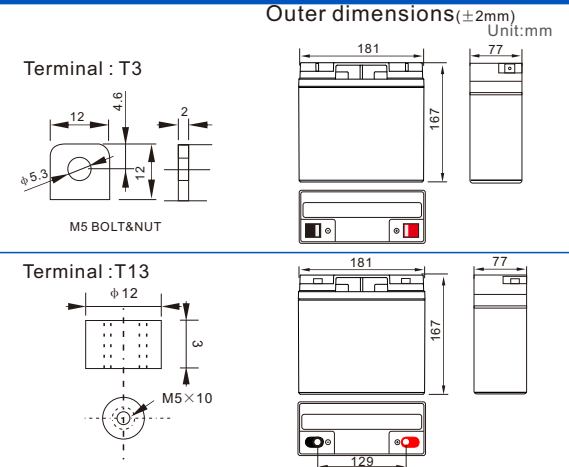

Characteristics

Capacity 25°C(77°F)	20 hour rate(1.1 A, 10.5V)	22 Ah
	10 hour rate(2.02A, 10.5V)	20.2Ah
	5 hour rate(3.77A, 10.5V) 1 hour rate(13.2 A, 9.6V)	18.85Ah 13.2Ah
Internal Resistance	Full charged battery at 25°C(77°F)	Approx 13 mΩ
Capacity affected by Temperature (20hour rate)	40°C (104°F)	102%
	25°C (77°F)	100%
	0°C (32°F) -15°C (5°F)	85% 65%
Remaining capacity Self-Discharge At 25°C(77°F)	Capacity after 3 month storage	91%
	Capacity after 6 month storage	82%
	Capacity after 12 month storage	64%
Terminal type	T3 (Option T3)	
Max. Discharge current 25°C/(77°F)	330A (5Seconds)	
Nominal operating temperature	25°C ±5°C(77°F ±9°F)	
Operating Temperature Range	Discharge	-15°C~50°C (5°F~122°F)
	Charge	-10°C~50°C (14°F~122°F)
	Storage	-20°C~50°C (-4°F~122°F)
Charge methods (constant Voltage) At 25°C(77°F)	Cycle use	Initial Charging Current less than 6.6 A Voltage 14.50-14.90V Temperature compensation:-30mV/°C
	Standby use	Voltage 13.50-13.80V Temperature compensation:-18mV/°C

Constant current discharge (25°C , 77 °F)

Constant power discharge (25°C , 77 °F)

Unit:A

Unit:watts

Time		5min	10min	15min	30min	1h	2h	3h	4h	5h	8h	10h	20h
9.60V	A	79.2	51.9	38.5	25.3	13.2	7.7	5.67	4.55	3.86	2.55	2.08	1.14
	W	934.1	586.7	443.7	268.6	152.2	89.1	65.54	52.62	44.64	29.43	24.11	13.20
10.20V	A	72.6	49.7	35.4	24.0	12.4	7.4	5.50	4.40	3.79	2.50	2.04	1.11
	W	879.1	555.5	417.1	266.8	143.0	85.5	63.71	50.97	43.82	28.97	23.65	12.83
10.50V	A	66.1	46.4	33.0	23.3	12.0	7.2	5.41	4.18	3.77	2.48	2.02	1.10
	W	848.8	539.0	398.8	264.0	138.8	83.9	62.61	48.40	43.54	28.69	23.47	12.74
10.80V	A	63.5	44.4	30.8	22.6	11.6	7.1	5.32	4.11	3.58	2.41	1.97	1.07
	W	744.3	522.5	384.1	263.1	134.8	82.1	61.88	47.80	41.62	27.50	22.92	12.47
11.10V	A	58.7	41.8	28.6	22.0	11.2	6.9	5.04	4.03	3.42	2.35	1.93	1.05
	W	719.6	505.1	365.8	261.3	132.9	81.6	60.04	47.67	40.70	26.58	22.46	12.38

(Above characteristics data are average values obtained within three charge/discharge cycles, not the minimum values.)

VRLA Battery (AGM technology) Maintenance-free Sealed Lead Acid Rechargeable Battery

Discharge characteristics (25°C, 77°F)

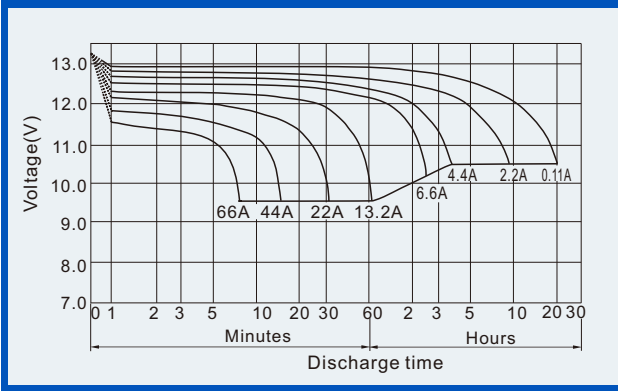

Charge characteristics (25°C, 77°F)

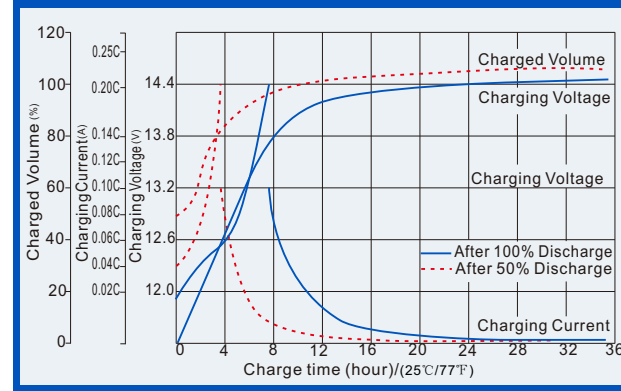

Life characteristics of Cyclic Use (25°C, 77°F)

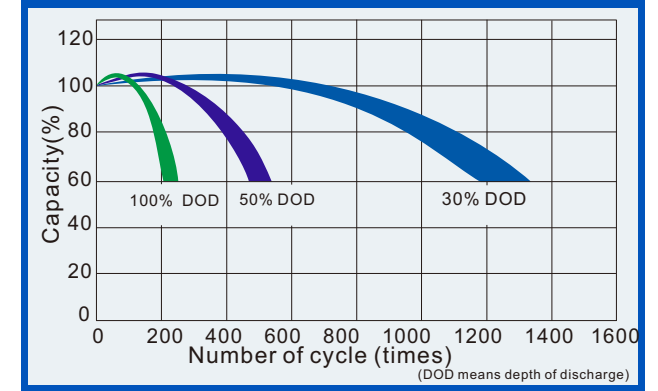

Effect of Temperature on capacity

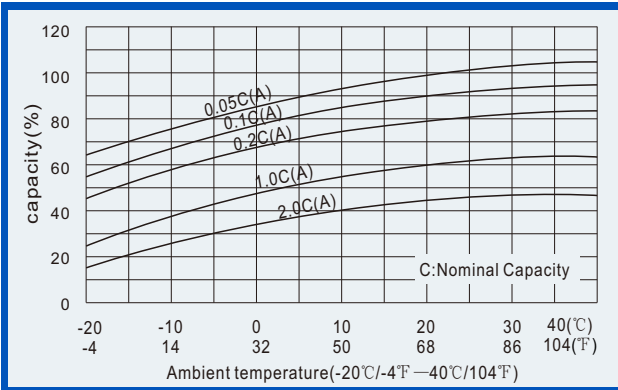

Self-discharge characteristics

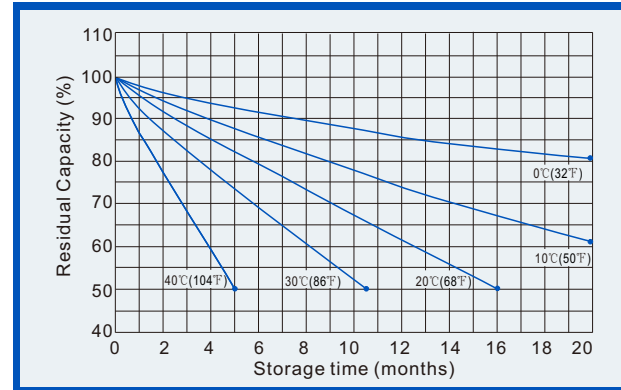

Life Characteristics of standby use (25°C, 77°F)

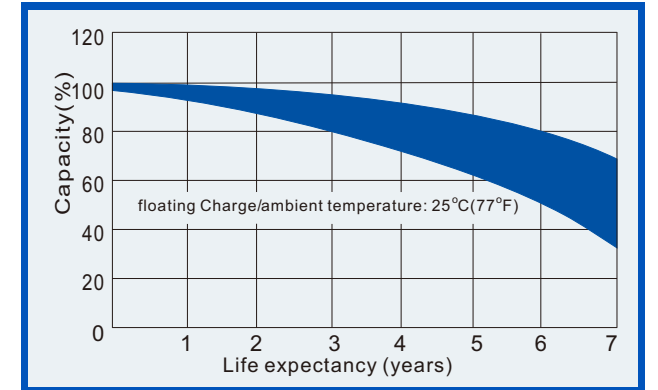

Relationships for open voltage and remained capacity (for reference)

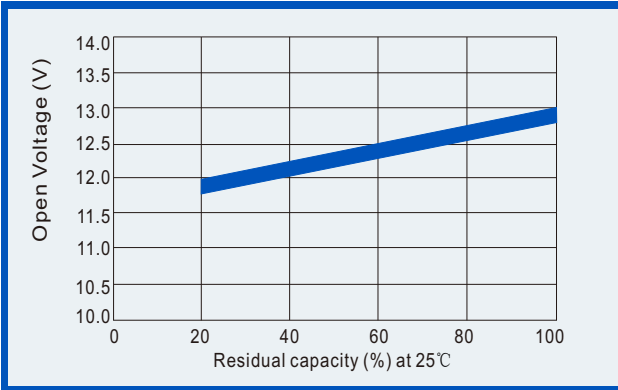

Relationship for charging voltage and temperature

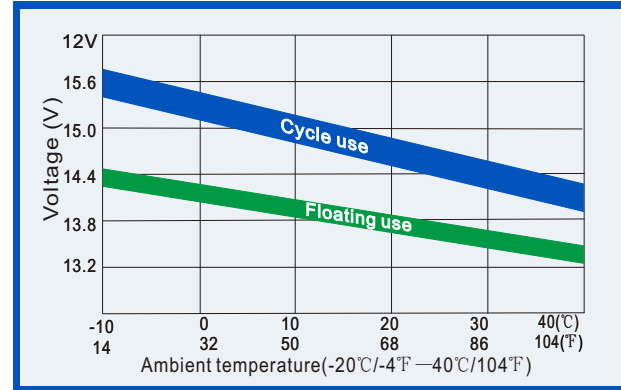

Temperature effects on floating life

