

### General features for MPa Series (AGM) battery

- \* Stable quality & high reliability.
- \* Unique construction and sealing technique guarantees.
- \* Design life 5years in float service; Long service life ,float or cyclic, which is shown in the specification sheet.
- \* Maintenance-free operation. UL-recognized component.
- \* Heavy duty grids: The heavy-duty lead calcium-alloy grids ,provide an extra margin of performance and service life in float & cyclic.
- \* Case and cover are available in both standard and flame retardant ABS.
- \* Low self discharge; low pressure venting system.



**Maxton Power Tech Co., Ltd**  
www.maxtonpower.com  
info@maxtonpower.com

**MP6-9 (6V9Ah)**

### Specifications

Nominal Voltage		6 V
Rated capacity (20 hour rate)		9.0 Ah
Dimensions (±1.5mm)	Total Height	118.5 mm(4.67 inches)
	Height	118.5mm(4.67inches)
	Length	98.5 mm(3.88 inches)
	Width	56.5 mm(2.22 inches)
Weight Approx (±3%)		1.20 Kg(2.65lbs)

### Battery picture and construction



#### Battery Construction

Component	Positive plate	Negative plate	Container	Cover
Raw material	Lead dioxide	Lead	ABS	ABS
Component	Electrolyte	Separator	Safety valve	Terminal
Raw material	Dilute sulfuric acid	Fiberglass	Rubber	Copper

### Outer dimension and terminal

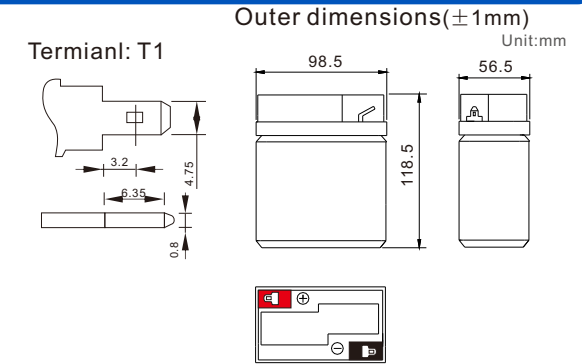

### Characteristics

Capacity 25°C(77°F)	20 hour rate(0.45 A,5.25V) 10 hour rate(0.83A,5.25V) 5 hour rate(1.5A,5.25V) 1 hour rate(5.4 A,4.8V)	9.0Ah 8.3Ah 7.5Ah 5.4 Ah
Internal Resistance	Full charged battery at 25°C(77°F)	Approx 11 mΩ
Capacity affected by Temperature (20hour rate)	40°C (104°F) 25°C (77°F) 0°C (32°F) -15°C (5°F)	102% 100% 85% 65%
Remaining capacity Self-Discharge At 25°C(77°F)	Capacity after 3 month storage Capacity after 6 month storage Capacity after 12 month storage	91% 82% 64%
Terminal type	T1	
Max. Discharge current 25°C/(77°F)	135A (5Seconds)	
Nominal operating temperature	25°C ±5°C(77°F ±9°F)	
Operating Temperature Range	Discharge Charge Storage	-15°C ~50°C (5°F ~122°F) -10°C ~50°C (14°F ~122°F) -20°C ~50°C (-4°F ~122°F)
Charge methods (constant Voltage) At 25°C(77°F)	Cycle use	Initial Charging Current less than 2.7A Voltage 7.05-7.20V Temperature compensation:-15mV/°C
	Standby use	Voltage 6.75-6.90V Temperature compensation:-9mV/°C

### Constant current discharge (25°C , 77 °F)

Unit:A

### Constant power discharge (25°C , 77 °F)

Unit:watts

#### Constant Current(Amp) and Constant Power(Watt) Discharge Table at 25°C(77°F)

Time		5min	10min	15min	30min	1h	2h	3h	4h	5h	8h	10h	20h
4.80V	A	32.40	20.30	15.75	10.35	5.40	3.15	2.32	1.86	1.58	1.04	0.85	0.465
	W	191.1	120.0	90.8	54.9	31.1	18.2	13.41	10.76	9.13	6.02	4.93	2.700
5.10V	A	29.70	19.87	14.47	9.83	5.07	3.02	2.25	1.80	1.55	1.02	0.836	0.454
	W	179.8	118.1	85.3	54.6	29.3	17.5	13.03	10.43	8.96	5.93	4.84	2.625
5.25V	A	27.54	18.99	13.50	9.52	4.91	2.96	2.21	1.71	1.54	1.01	0.83	0.450
	W	173.6	110.3	81.6	54.0	28.4	17.2	12.81	9.90	8.91	5.87	4.80	2.606
5.40V	A	25.08	18.15	12.60	9.09	4.74	2.89	2.18	1.68	1.46	0.99	0.81	0.439
	W	165.7	106.9	78.6	53.8	27.6	16.8	12.66	9.78	8.51	5.63	4.69	2.550
5.55V	A	21.69	17.10	11.70	8.46	4.57	2.81	2.06	1.65	1.40	0.96	0.79	0.428
	W	129.2	103.3	74.8	53.4	27.2	16.7	12.28	9.75	8.33	5.44	4.59	2.531

(Above characteristics data are average values obtained within three charge/discharge cycles,not the minimum values.)

# VRLA Battery (AGM technology) Maintenance-free Sealed Lead Acid Rechargeable Battery

**Discharge characteristics (25°C, 77°F)**

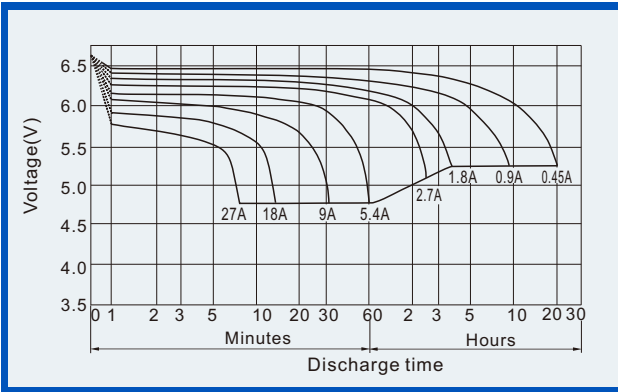

**Charge characteristics (25°C, 77°F)**

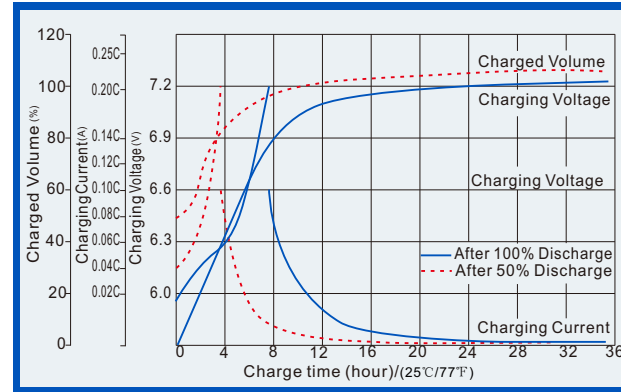

**Life characteristics of Cyclic Use (25°C, 77°F)**

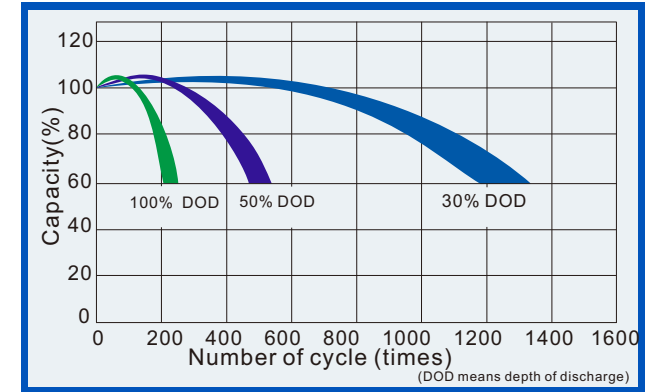

**Effect of Temperature on capacity**

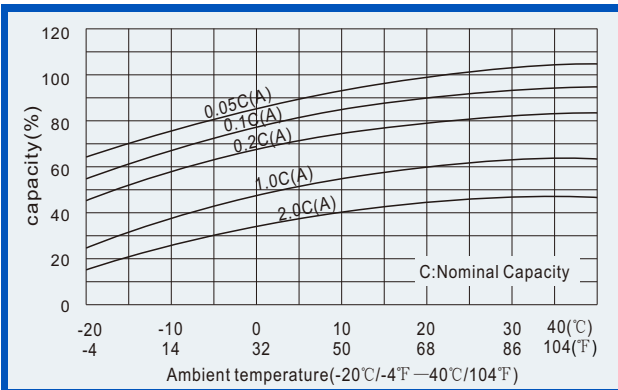

**Self-discharge characteristics**

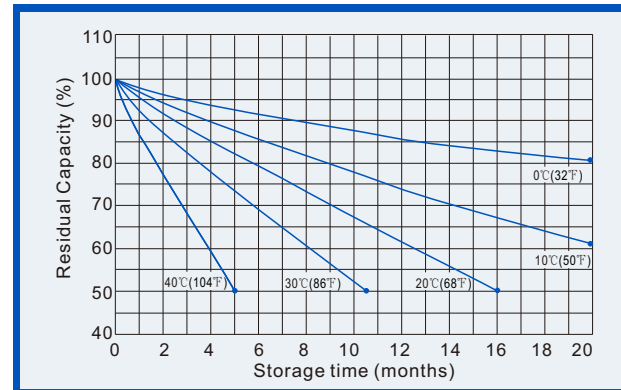

**Life Characteristics of standby use (25°C, 77°F)**

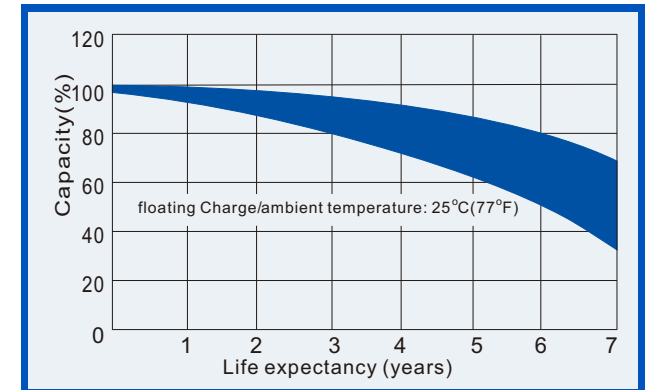

**Relationships for open voltage and remained capacity (for reference)**

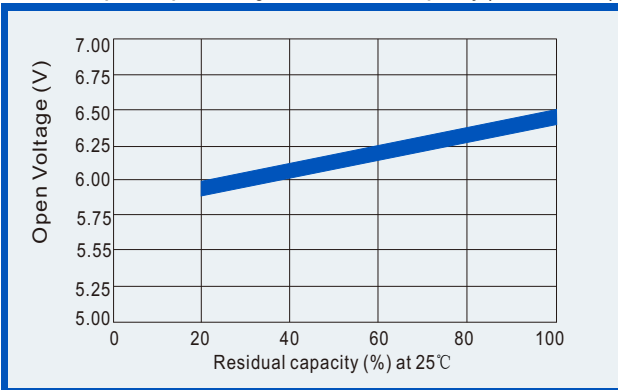

**Relationship for charging voltage and temperature**

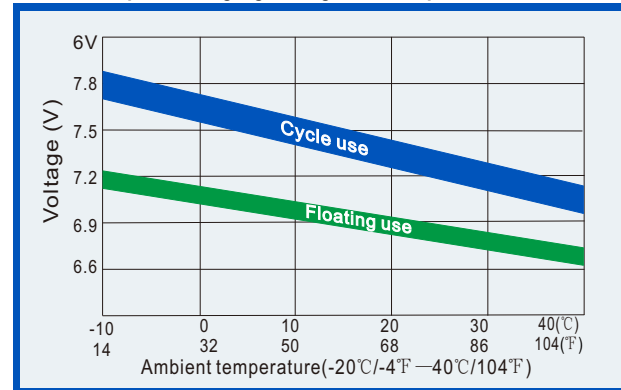

**Temperature effects on floating life**

