

### General features for MPa Series (AGM) battery

- \* Stable quality & high reliability.
- \* Unique construction and sealing technique guarantees.
- \* Design life 5years in float service; Long service life ,float or cyclic, which is shown in the specification sheet.
- \* Maintenance-free operation. UL-recognized component.
- \* Heavy duty grids: The heavy-duty lead calcium-alloy grids ,provide an extra margin of performance and service life in float & cyclic.
- \* Case and cover are available in both standard and flame retardant ABS.
- \* Low self discharge; low pressure venting system.



**Maxton Power Tech Co., Ltd**  
www.maxtonpower.com  
info@maxtonpower.com

**MP8-3.2 (8V3.2Ah)**

### Specifications

Nominal Voltage		8 V
Rated capacity (20 hour rate)		3.2 Ah
Dimensions (±1mm)	Total Height	90.5 mm (3.56 inches)
	Height	90.5 mm(3.56 inches)
	Length	67.5 mm(2.66 inches)
	Width	48.5 mm(1.91 inches)
Weight Approx(±3%)		0.73 Kg (1.61 lbs)

### Battery picture and construction



#### Battery Construction

Component	Positive plate	Negative plate	Container	Cover
Raw material	Lead dioxide	Lead	ABS	ABS
Component	Electrolyte	Separator	Safety valve	Terminal
Raw material	Dilute sulfuric acid	Fiberglass	Rubber	Copper

### Outer dimension and terminal

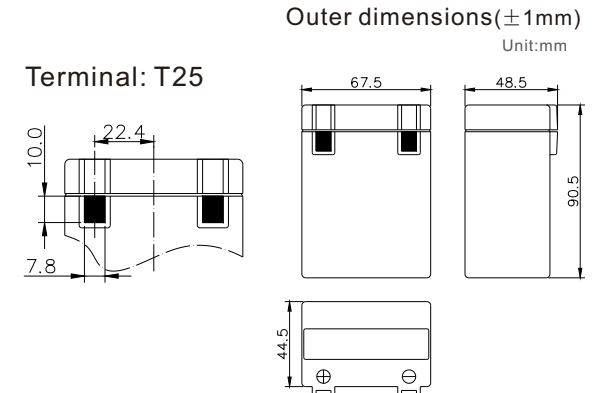

### Characteristics

Capacity 25°C(77°F)	20 hour rate(0.16 A, 7.0V)	3.2Ah
	10 hour rate(0.3A, 7.0V)	3.0Ah
	5 hour rate(0.54A, 7.0V)	2.7Ah
	1 hour rate(2.08A, 6.4V)	2.08 Ah
Internal Resistance	Full charged battery at 25°C(77°F)	Approx 32 mΩ
Capacity affected by Temperature (20hour rate)	40°C (104°F)	102%
	25°C (77°F)	100%
	0°C (32°F)	85%
	-15°C (5°F)	65%
Remaining capacity Self-Discharge At 25°C(77°F)	Capacity after 3 month storage	91%
	Capacity after 6 month storage	82%
	Capacity after 12 month storage	64%
Terminal type	T25	
Max. Discharge current 25°C/(77°F)	48A (5Seconds)	
Nominal operating temperature	25°C ±5°C(77°F ±9°F)	
Operating Temperature Range	Discharge	-15°C ~50°C (5°F ~122°F)
	Charge	-10°C ~50°C (14°F ~122°F)
	Storage	-20°C ~50°C (-4°F ~122°F)
Charge methods (constant Voltage) At 25°C(77°F)	Cycle use	Initial Charging Current less than 0.96A Voltage 9.4-9.6V Temperature compensation:-20mV/°C
	Standby use	Voltage 9.0-9.2V Temperature compensation:-12mV/°C

### Constant current discharge (25°C , 77 °F)

Unit:A

### Constant power discharge (25°C , 77 °F)

Unit:watts

Constant Current(Amp) and Constant Power(Watt) Discharge Table at 25°C(77°F)													
Time		5min	10min	15min	30min	1h	2h	3h	4h	5h	8h	10h	20h
6.40V	A	11.52	7.22	5.60	3.68	1.92	1.12	0.82	0.66	0.56	0.37	0.30	0.17
	W	67.9	42.7	32.3	19.5	11.1	6.5	4.77	3.83	3.25	2.14	1.75	0.96
6.80V	A	10.56	7.07	5.15	3.49	1.80	1.07	0.80	0.64	0.55	0.36	2.97	0.16
	W	63.9	42.0	30.3	19.4	10.4	6.2	4.63	3.71	3.19	2.11	1.72	0.93
7.00V	A	9.79	6.75	4.80	3.39	1.74	1.05	0.79	0.61	0.55	0.36	0.29	0.16
	W	61.7	39.2	29.0	19.2	10.1	6.1	4.55	3.52	3.17	2.09	1.71	0.93
7.20V	A	8.92	6.45	4.48	3.23	1.69	1.03	0.77	0.60	0.52	0.35	0.29	0.16
	W	58.9	38.0	27.9	19.1	9.8	6.0	4.50	3.48	3.03	2.00	1.67	0.91
7.40V	A	7.71	6.08	4.16	3.01	1.63	1.00	0.73	0.59	0.50	0.34	0.28	0.15
	W	45.9	36.7	26.6	19.0	9.7	5.9	4.37	3.47	2.96	1.93	1.63	0.90

(Above characteristics data are average values obtained within three charge/discharge cycles, not the minimum values.)

# VRLA Battery (AGM technology) Maintenance-free Sealed Lead Acid Rechargeable Battery

**Discharge characteristics (25°C, 77°F)**

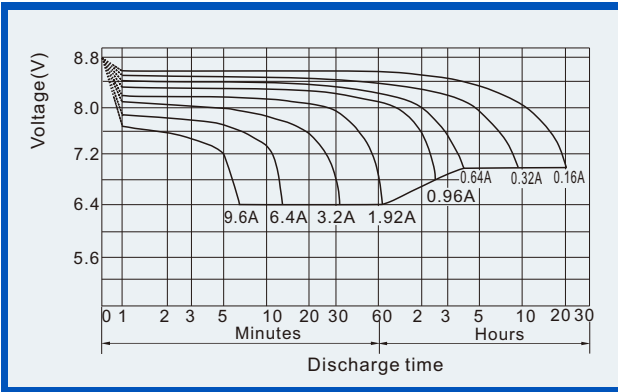

**Charge characteristics (25°C, 77°F)**

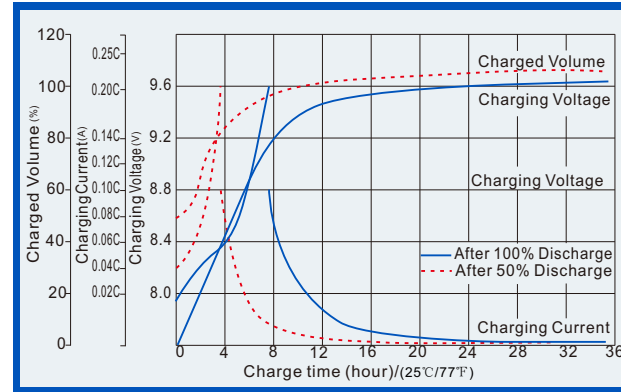

**Life characteristics of Cyclic Use (25°C, 77°F)**

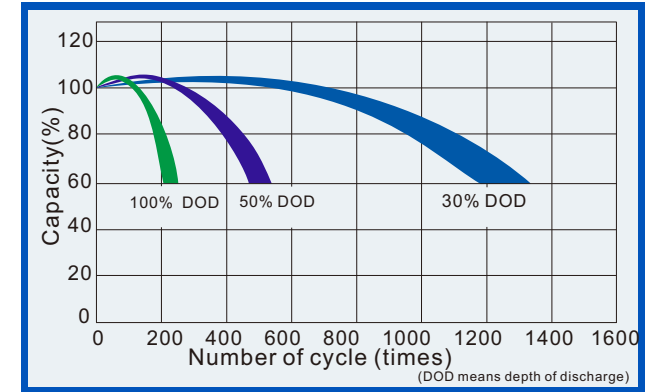

**Effect of Temperature on capacity**

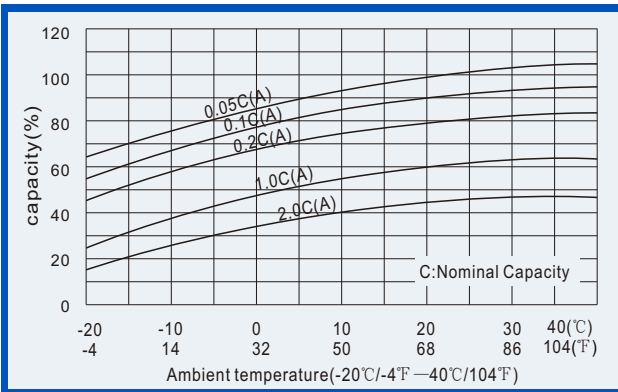

**Self-discharge characteristics**

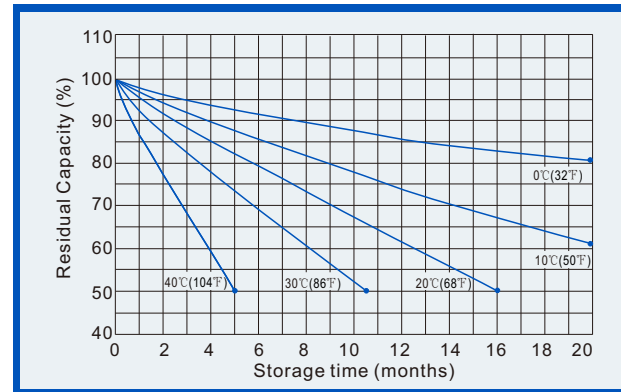

**Life Characteristics of standby use (25°C, 77°F)**

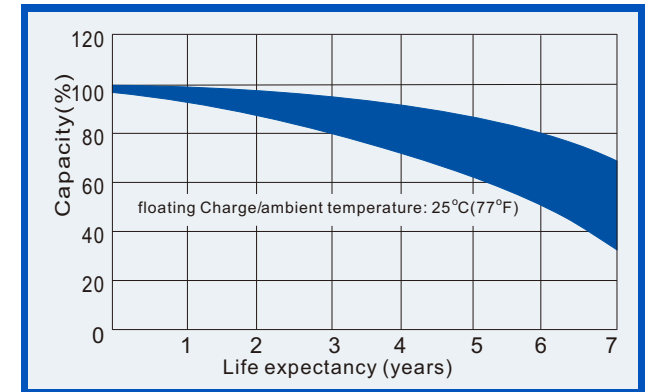

**Relationships for open voltage and remained capacity (for reference)**

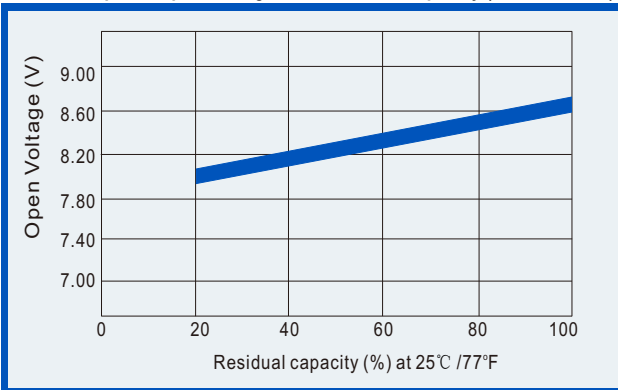

**Relationship for charging voltage and temperature**

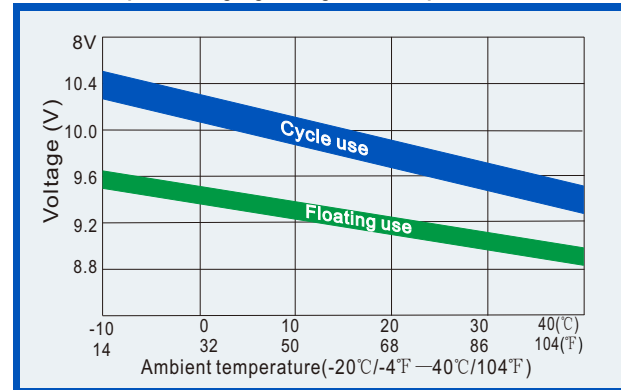

**Temperature effects on floating life**

