

### General features for MPb Series (AGM) battery

- \* Stable quality & high reliability.
- \* Unique construction and sealing technique guarantees.
- \* Design life 10years in float service;the battery comply to the most popular international standards,like IEC60896-21/22,etc
- \* Maintenance-free operation.
- \* UL-recognized component.
- \* Heavy duty grids:  
The heavy-duty lead calcium-alloy grids ,provide an extra margin of performance and service life in float & cyclic.
- \* Case and cover are available in both standard and flame retardant ABS.
- \* Low self discharge;low pressure venting system.



**Maxton Power Tech Co.,Ltd**  
www.maxtonpower.com  
info@maxtonpower.com

## MP12-134 (12V134Ah)

### Specifications

Nominal Voltage		12V
Rated capacity (10 hour rate)		134 Ah
Dimensions (±2mm)	Total Height	288 mm (11.33 inches)
	Height	283 mm (11.14 inches)
	Length	341 mm (13.42 inches)
	Width	173mm (6.81 inches)
Weight Approx (±3%)		39.0Kg (85.98 lbs)

### Battery picture and construction



#### Battery Construction

Component	Positive plate	Negative plate	Container	Cover
Raw material	Lead dioxide	Lead	ABS	ABS
Component	Electrolyte	Separator	Safety valve	Terminal
Raw material	Dilute sulfuric acid	Fiberglass	Rubber	Copper

### Outer dimension and terminal

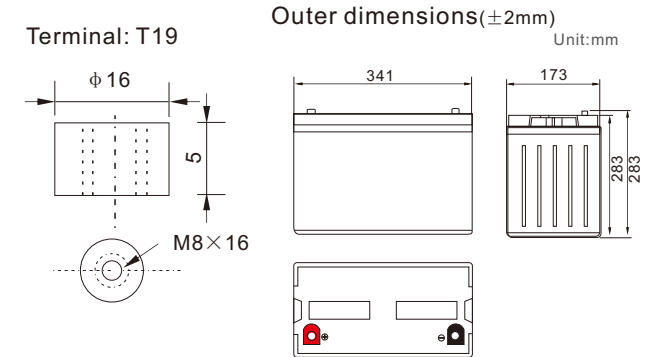

### Characteristics

Capacity 25°C(77°F)	10 hour rate(13.4 A,10.8V) 5 hour rate(21.4A,10.5V) 1 hour rate(80.4 A,9.6V)	134Ah 107Ah 80.4Ah
Internal Resistance	Full charged battery at 25°C(77°F)	Approx 3.8 mΩ
Capacity affected by Temperature (10hour rate)	40°C (104°F) 25°C (77°F) 0°C (32°F) -15°C (5°F)	102% 100% 85% 65%
Remaining capacity Self-Discharge At 25°C(77°F)	Capacity after 3 month storage Capacity after 6 month storage Capacity after 12 month storage	91% 82% 64%
Terminal type	T19	
Max. Discharge current 25°C/(77°F)	950A (5Seconds)	
Nominal operating temperature	25°C ±5°C(77°F ±9°F)	
Operating Temperature Range	Discharge Charge Storage	-15°C ~50°C (5°F ~122°F) -10°C ~50°C (14°F ~122°F) -20°C ~50°C (-4°F ~122°F)
Charge methods (constant Voltage) At 25°C(77°F)	Cycle use	Initial Charging Current less than 33.5 A Voltage 14.5-14.9V Temperature compensation:-30mV/°C
	Standby use	Voltage 13.8-13.8V Temperature compensation:-18mV/°C

### Constant current discharge (25°C , 77 °F)

### Constant power discharge (25°C , 77 °F)

Unit:A

Unit:watts

Time	5min	10min	15min	30min	1h	2h	3h	4h	5h	8h	10h	20h
9.60V	A	429	283	228	152.8	80.4	46.9	34.4	26.8	22.1	15.68	7.60
	W	4429	3020	2444	1642	868	515	383	302	251	180	88.3
10.20V	A	416	255	215	146.1	75.6	44.8	33.5	26.1	21.7	15.28	7.37
	W	4439	2849	2402	1640	855	516	388	304	253	179	86.5
10.50V	A	402	228	188	136.7	73.2	43.7	32.7	25.7	21.4	15.14	7.37
	W	4391	2596	2142	1573	847	507	381	301	251	178	87.1
10.80V	A	388	215	174	126.0	70.8	42.6	31.9	25.3	20.9	14.74	7.24
	W	4348	2480	2010	1459	824	499	376	299	247	175	86.2
11.10V	A	375	202	161	112.6	68.3	41.5	30.8	24.7	20.4	14.34	6.83
	W	4247	2334	1875	1317	804	491	366	294	243	172	82.8

(Above characteristics data are average values obtained within three charge/discharge cycles,not the minimum values.)

# VRLA Battery (AGM technology) Maintenance-free Sealed Lead Acid Rechargeable Battery

**Discharge characteristics (25°C, 77°F)**

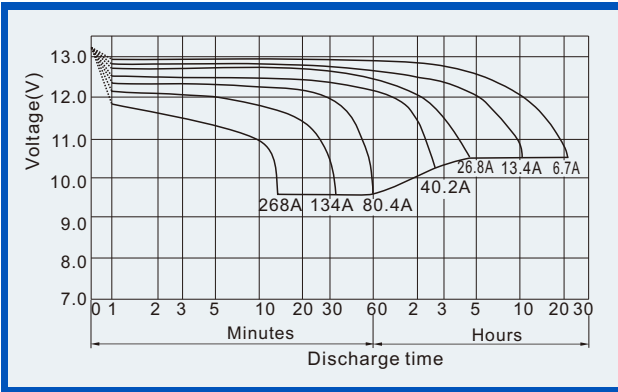

**Charge characteristics (25°C, 77°F)**

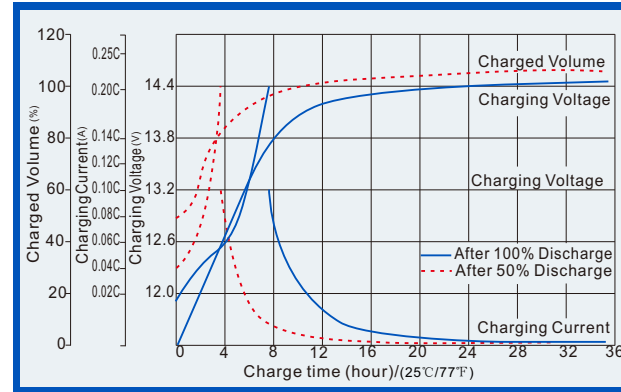

**Life characteristics of Cyclic Use (25°C, 77°F)**

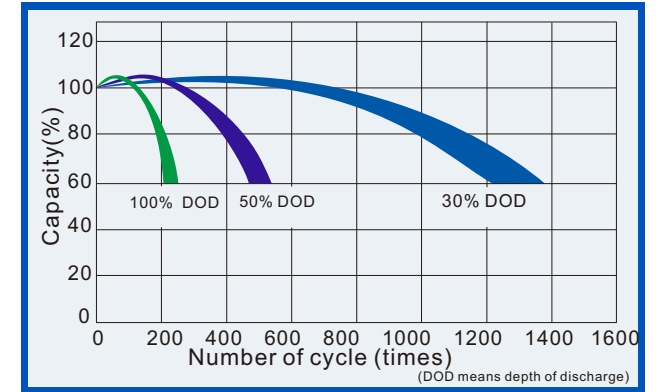

**Effect of Temperature on capacity**



**Self-discharge characteristics**



**Life Characteristics of float service (25°C, 77°F)**

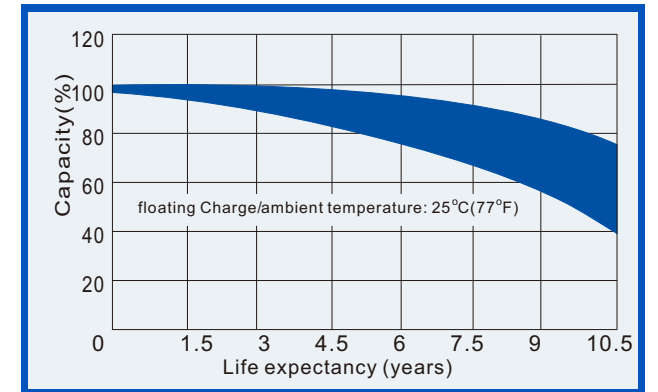

**Relationships for open voltage and remained capacity (for reference)**

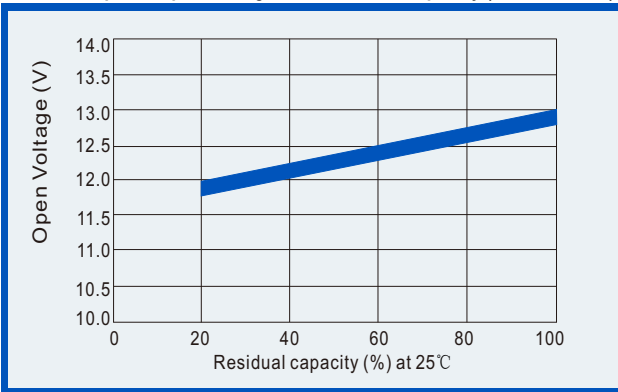

**Relationship for charging voltage and temperature**

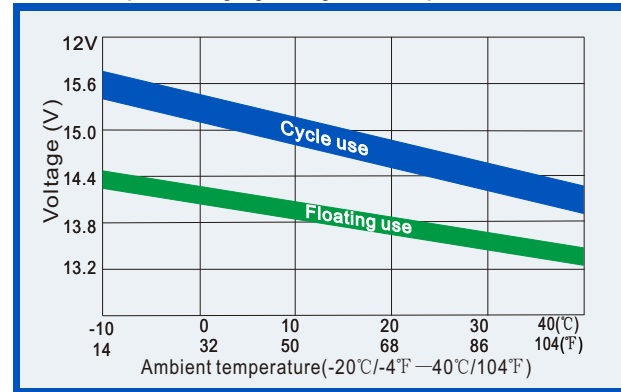

**Temperature effects on floating life**

