

## General features for MPb Series (AGM) battery

- \* Stable quality & high reliability.
- \* Unique construction and sealing technique guarantees.
- \* Design life 10years in float service;the battery comply to the most popular international standards,like IEC60896-21/22,etc
- \* Maintenance-free operation.
- \* UL-recognized component.
- \* Heavy duty grids:  
The heavy-duty lead calcium-alloy grids ,provide an extra margin of performance and service life in float & cyclic.
- \* Case and cover are available in both standard and flame retardant ABS.
- \* Low self discharge;low pressure venting system.



**Maxton Power Tech Co.,Ltd**  
www.maxtonpower.com  
info@maxtonpower.com

**MP12-55 (12V55Ah)**

## Specifications

Nominal Voltage		12V	
Rated capacity (10 hour rate)		55 Ah	
Dimensions (±2mm)	Total Height	T16	216 mm (8.50 inches)
		T9	228 mm (8.98 inches)
	Height	208 mm (8.19 inches)	
	Length	230 mm (9.1 inches)	
Weight Approx (±3%)		15.8Kg (34.85 lbs)	

## Battery picture and construction



### Battery Construction

Component	Positive plate	Negative plate	Container	Cover
Raw material	Lead dioxide	Lead	ABS	ABS
Component	Electrolyte	Separator	Safety valve	Terminal
Raw material	Dilute sulfuric acid	Fiberglass	Rubber	Copper

## Outer dimension and terminal

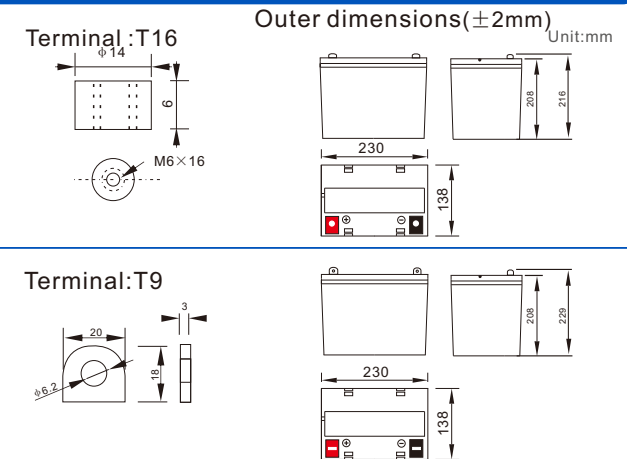

## Characteristics

Capacity 25°C(77°F)	10 hour rate(5.5A,10.8V) 5 hour rate(8.8A,10.5V) 1 hour rate(33A,9.6V)	55Ah 44Ah 33Ah
Internal Resistance	Full charged battery at 25°C(77°F)	Approx 6.5 mΩ
Capacity affected by Temperature (10hour rate)	40°C (104°F) 25°C (77°F) 0°C (32°F) -15°C (5°F)	102% 100% 85% 65%
Remaining capacity Self-Discharge At 25°C(77°F)	Capacity after 3 month storage Capacity after 6 month storage Capacity after 12 month storage	91% 82% 64%
Terminal type	T16 (Option T9)	
Max. Discharge current 25°C/(77°F)	550A (5Seconds)	
Nominal operating temperature	25°C ±5°C(77°F ±9°F)	
Operating Temperature Range	Discharge Charge Storage	-15°C ~50°C (5°F ~122°F) -10°C ~50°C (14°F ~122°F) -20°C ~50°C (-4°F ~122°F)
Charge methods (constant Voltage) At 25°C(77°F)	Cycle use	Initial Charging Current less than 13.8A Voltage 14.5-14.9V Temperature compensation:-30mV/°C
	Standby use	Voltage 13.5-13.8V Temperature compensation:-18mV/°C

## Constant current discharge (25°C , 77 °F)

## Constant power discharge (25°C , 77 °F)

Unit:A

Unit:watts

### Constant Current(Amp) and Constant Power(Watt) Discharge Table at 25°C(77°F)

Time	5min	10min	15min	30min	1h	2h	3h	4h	5h	8h	10h	20h
9.60V	A	204	149	105	63	33	19	14.1	11.0	9.1	6.4	3.12
	W	2161	1577	1110	672	382	223	164	127	105	74	36.1
10.20V	A	179	135	94	60.0	31.0	18.4	13.8	10.7	8.9	6.3	3.04
	W	1990	1502	1038	665	359	213	159	124	103	72	35.2
10.50V	A	173	129	88	58	30	17.9	13.4	10.6	8.8	6.2	3.00
	W	1958	1459	998	661	348	208	155	122	102	72	34.8
10.80V	A	166	122	83	57	29	17.5	13.1	10.4	8.6	6.1	2.97
	W	1933	1421	960	659	338	204	152	120	100	70	34.6
11.10V	A	160	116	77	55	28	17.1	12.7	10.1	8.4	5.23	2.82
	W	1898	1374	916	655	334	203	151	119	99	70	33.6

(Above characteristics data are average values obtained within three charge/discharge cycles,not the minimum values.)

# VRLA Battery (AGM technology) Maintenance-free Sealed Lead Acid Rechargeable Battery

**Discharge characteristics (25°C, 77°F)**

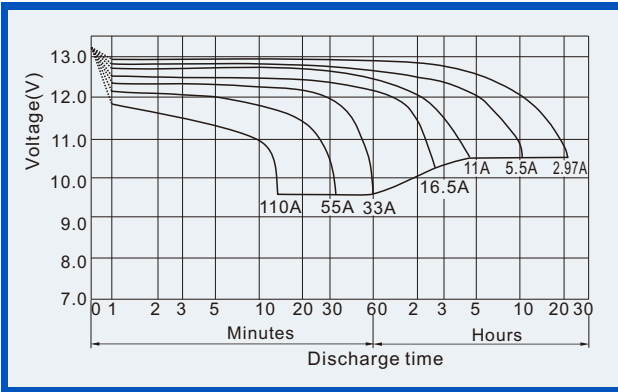

**Charge characteristics (25°C, 77°F)**

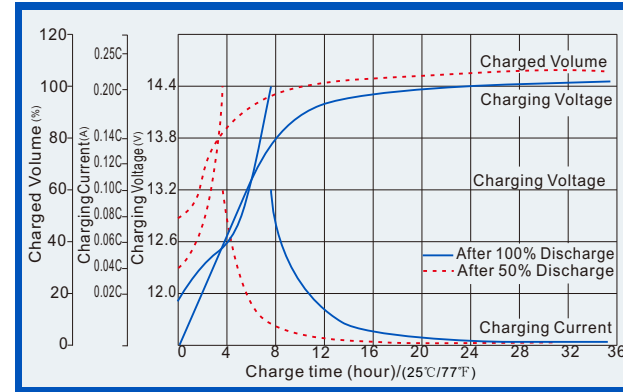

**Life characteristics of Cyclic Use (25°C, 77°F)**

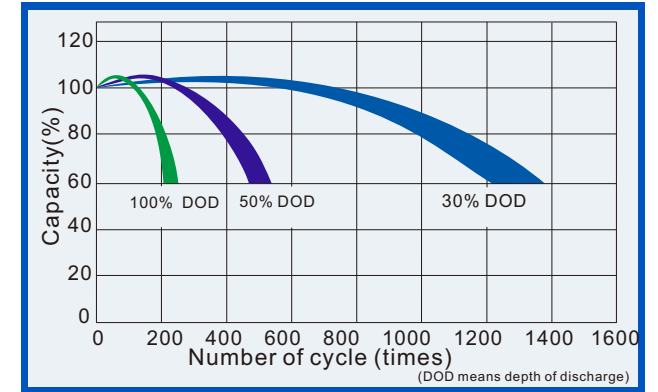

**Effect of Temperature on capacity**

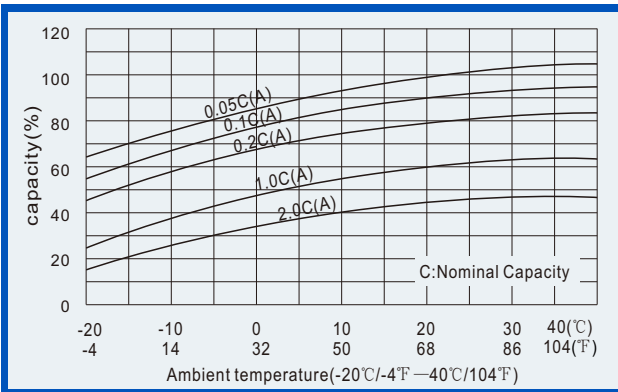

**Self-discharge characteristics**

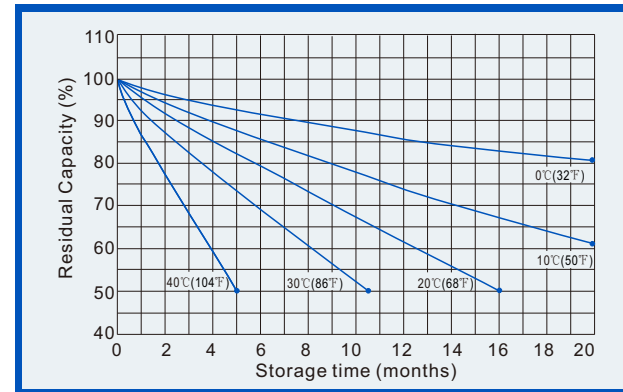

**Life Characteristics of float service (25°C, 77°F)**

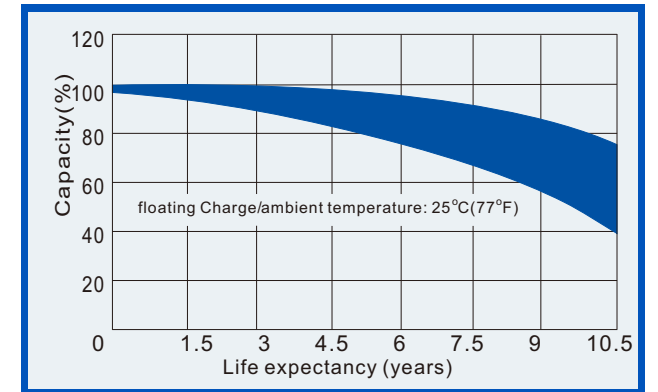

**Relationships for open voltage and remained capacity (for reference)**

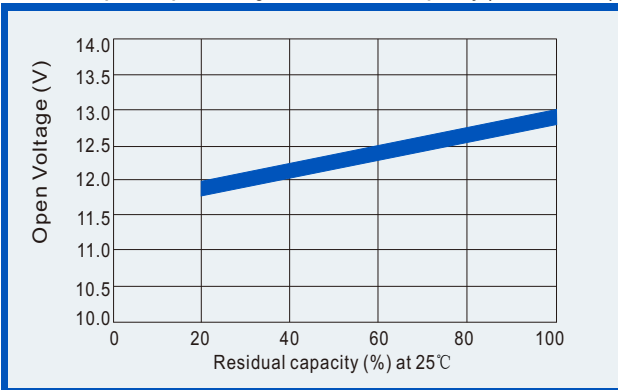

**Relationship for charging voltage and temperature**

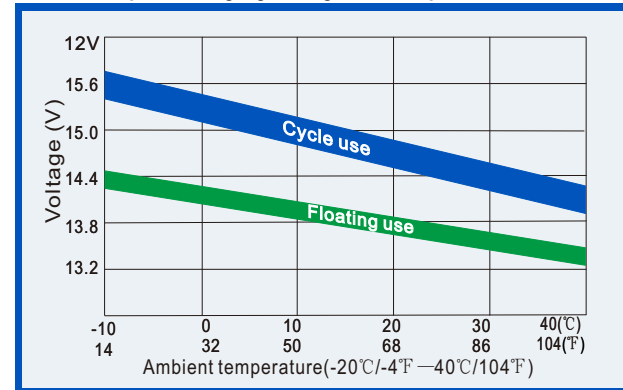

**Temperature effects on floating life**

