

### General features for MPb Series (AGM) battery

- \* Stable quality & high reliability.
- \* Unique construction and sealing technique guarantees.
- \* Design life 10years in float service;the battery comply to the most popular international standards,like IEC60896-21/22,etc
- \* Maintenance-free operation.
- \* UL-recognized component.
- \* Heavy duty grids:  
The heavy-duty lead calcium-alloy grids ,provide an extra margin of performance and service life in float & cyclic.
- \* Case and cover are available in both standard and flame retardant ABS.
- \* Low self discharge;low pressure venting system.



**Maxton Power Tech Co.,Ltd**  
www.maxtonpower.com  
info@maxtonpower.com

## MP12-70II (12V70Ah)

### Specifications

Nominal Voltage		12V	
Rated capacity (10 hour rate)		70Ah	
Dimensions (±2mm)	Total Height	T16	179mm (7.05 inches)
		T9	179 mm (7.05 inches)
	Height	179 mm (7.05 inches)	
	Length	350 mm (130.8 inches)	
	Width	166 mm (6.54 inches)	
Weight Approx (±3%)		21.0 Kg (46.3 lbs)	

### Battery picture and construction



#### Battery Construction

Component	Positive plate	Negative plate	Container	Cover
Raw material	Lead dioxide	Lead	ABS	ABS
Component	Electrolyte	Separator	Safety valve	Terminal
Raw material	Dilute sulfuric acid	Fiberglass	Rubber	Copper

### Outer dimension and terminal

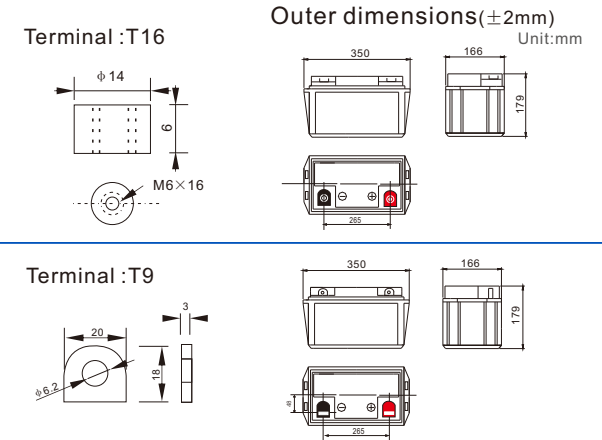

### Characteristics

Capacity 25°C(77°F)	10 hour rate(7.0 A, 10.8V) 5 hour rate(11.2A, 10.5V) 1 hour rate(42 A, 9.6V)	70Ah 56Ah 42Ah
Internal Resistance	Full charged battery at 25°C(77°F)	Approx 5.5 mΩ
Capacity affected by Temperature (10hour rate)	40°C (104°F) 25°C (77°F) 0°C (32°F) -15°C (5°F)	102% 100% 85% 65%
Remaining capacity Self-Discharge At 25°C(77°F)	Capacity after 3 month storage Capacity after 6 month storage Capacity after 12 month storage	91% 82% 64%
Terminal type	T16 (Option T9)	
Max. Discharge current 25°C/(77°F)	700A (5Seconds)	
Nominal operating temperature	25°C ±5°C(77°F ±9°F)	
Operating Temperature Range	Discharge Charge Storage	-15°C ~50°C (5°F ~122°F) -10°C ~50°C (14°F ~122°F) -20°C ~50°C (-4°F ~122°F)
Charge methods (constant Voltage) At 25°C(77°F)	Cycle use Standby use	Initial Charging Current less than 17.5A Voltage 14.5-14.9V Temperature compensation:-30mV/°C Voltage 13.6-13.8V Temperature compensation:-18mV/°C

### Constant current discharge (25°C , 77 °F)

### Constant power discharge (25°C , 77 °F)

Unit:A

Unit:watts

Time	5min	10min	15min	30min	1h	2h	3h	4h	5h	8h	10h	20h
9.60V	A	259	189	133	81	42	25	18.0	14.0	11.6	8.1	3.97
	W	2750	2007	1412	855	486	284	208	162	134	94	46.0
10.20V	A	228	172	119	76.3	39.5	23.4	17.5	13.7	11.3	8.0	3.87
	W	2533	1911	1321	847	457	271	203	158	131	92	44.8
10.50V	A	220	164	112	74	38	22.8	17.1	13.4	11.2	7.9	3.82
	W	2493	1857	1270	841	443	264	198	156	130	92	44.3
10.80V	A	211	155	105	72	37	22.3	16.7	13.2	10.9	7.7	3.78
	W	2461	1809	1222	839	430	259	194	152	127	90	44.0
11.10V	A	203	147	98	70	36	21.7	16.1	12.8	10.6	7.5	3.59
	W	2416	1749	1166	833	425	258	192	152	127	89	42.7

(Above characteristics data are average values obtained within three charge/discharge cycles,not the minimum values.)

# VRLA Battery (AGM technology) Maintenance-free Sealed Lead Acid Rechargeable Battery

**Discharge characteristics (25°C, 77°F)**

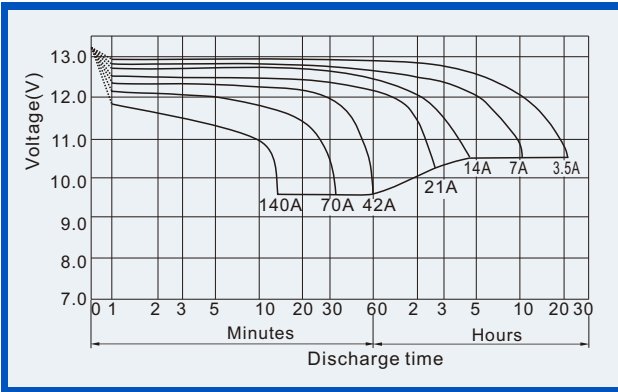

**Charge characteristics (25°C, 77°F)**

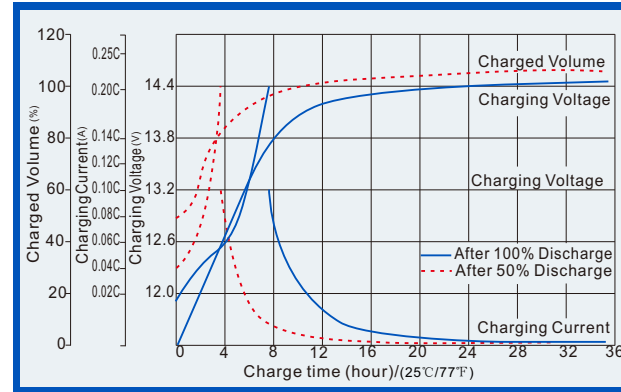

**Life characteristics of Cyclic Use (25°C, 77°F)**

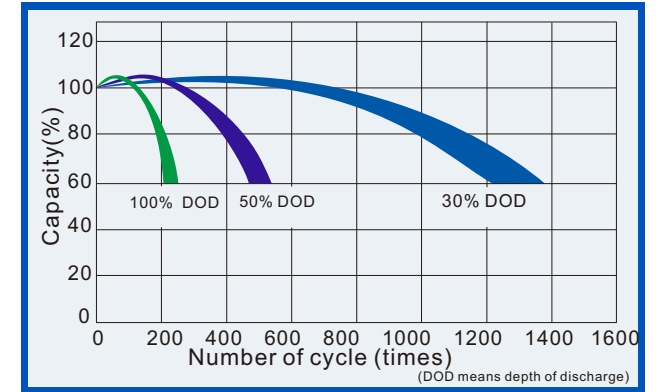

**Effect of Temperature on capacity**



**Self-discharge characteristics**



**Life Characteristics of float service (25°C, 77°F)**

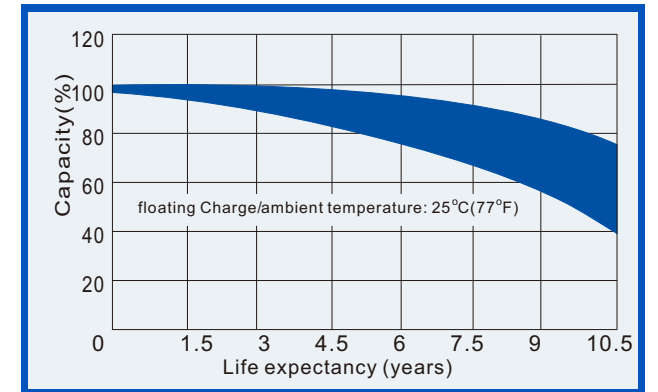

**Relationships for open voltage and remained capacity (for reference)**

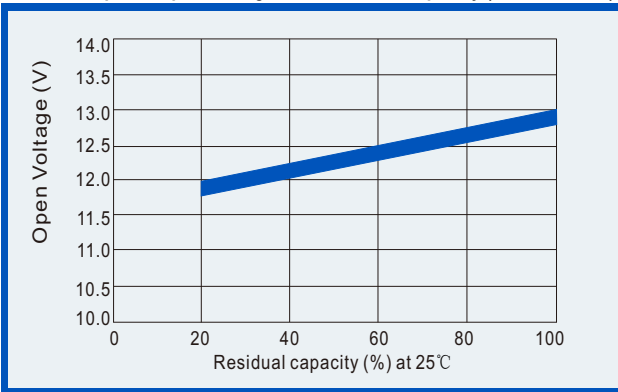

**Relationship for charging voltage and temperature**

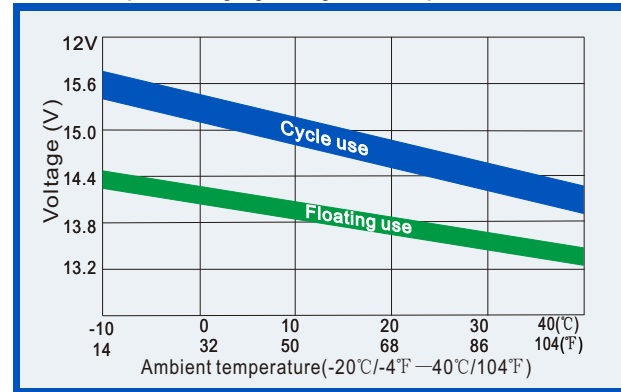

**Temperature effects on floating life**

