

General features for MPb Series (AGM) battery

- * Stable quality & high reliability.
- * Unique construction and sealing technique guarantees.
- * Design life 10years in float service;the battery comply to the most popular international standards,like IEC60896-21/22,etc
- * Maintenance-free operation.
- * UL-recognized component.
- * Heavy duty grids:
The heavy-duty lead calcium-alloy grids ,provide an extra margin of performance and service life in float & cyclic.
- * Case and cover are available in both standard and flame retardant ABS.
- * Low self discharge;low pressure venting system.



Maxton Power Tech Co.,Ltd
www.maxtonpower.com
info@maxtonpower.com

MP6-180 (6V180Ah)

Specifications

Nominal Voltage		6V
Rated capacity (10 hour rate)		180 Ah
Dimensions (±2mm)	Total Height	252mm (9.92 inches)
	Height	247 mm (9.72 inches)
	Length	260 mm (10.2 inches)
	Width	180 mm (7.09 inches)
Weight Approx (±3%)		26.0 Kg (57.4 lbs)

Battery picture and construction



Battery Construction

Component	Positive plate	Negative plate	Container	Cover
Raw material	Lead dioxide	Lead	ABS	ABS
Component	Electrolyte	Separator	Safety valve	Terminal
Raw material	Dilute sulfuric acid	Fiberglass	Rubber	Copper

Outer dimension and terminal

Outer dimensions(±2mm) Unit:mm

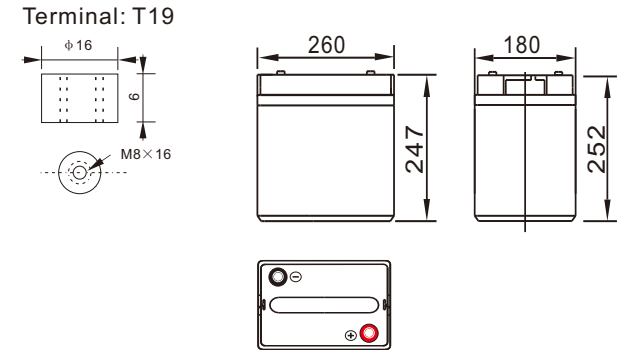

Characteristics

Capacity 25°C(77°F)	10 hour rate (18.0 A,5.4V)	180Ah
	5 hour rate (28.8A,5.25V)	144Ah
	1 hour rate (108 A,4.8V)	108Ah
Internal Resistance	Full charged battery at 25°C(77°F)	Approx.1.5mΩ
Capacity affected by Temperature (10hour rate)	40°C (104°F)	102%
	25°C (77°F)	100%
	0°C (32°F)	85%
	-15°C (5°F)	65%
Remaining capacity Self-Discharge At 25°C(77°F)	Capacity after 3 month storage	91%
	Capacity after 6 month storage	82%
	Capacity after 12 month storage	64%
Terminal type		T19
Max. Discharge current 25°C/(77°F)		1400A (5Seconds)
Nominal operating temperature		25°C ±5°C(77°F ±9°F)
Operating Temperature Range	Discharge	-15°C ~50°C (5°F ~122°F)
	Charge	-10°C ~50°C (14°F ~122°F)
	Storage	-20°C ~50°C (-4°F ~122°F)
Charge methods (constant Voltage) At 25°C(77°F)	Cycle use	Initial Charging Current less than 45 A Voltage 7.25-7.45V Temperature compensation:-15mV/°C
	Standby use	Voltage 6.75-6.90V Temperature compensation:-9mV/°C

Constant current discharge (25°C , 77 °F)

Unit:A

Constant power discharge (25°C , 77 °F)

Unit:watts

Time	Constant Current(Amp) and Constant Power(Watt) Discharge Table at t 25°C(77 °F)												
	5min	10min	15min	30min	1h	2h	3h	4h	5h	8h	10h	20h	
4.80V	A	577	380	306	205	108	63.0	46.3	36.0	29.7	21.1	18.9	10.2
	W	2975	2028	1641	1103	583	346	257	203	169	121	109	59.3
5.10V	A	558	343	288	196	102	60.1	45.0	35.1	29.2	20.5	18.5	9.90
	W	2982	1913	1613	1101	574	346	261	204	170	120	109	58.1
5.25V	A	540	307	252	184	98	58.7	43.9	34.6	28.8	20.3	18.2	9.9
	W	2949	1744	1439	1056	569	340	256	202	169	120	108	58.5
5.40V	A	521	289	234	169	95	57.2	42.8	34.0	28.1	19.8	18.0	9.72
	W	2920	1666	1350	980	553	335	253	201	166	117	107	57.9
5.55V	A	503	271	216	151	92	55.8	41.4	33.1	27.4	19.3	17.1	9.18
	W	2853	1567	1259	885	540	330	246	197	163	115	103	55.6

(Above characteristics data are average values obtained within three charge/discharge cycles,not the minimum values.)

VRLA Battery (AGM technology) Maintenance-free Sealed Lead Acid Rechargeable Battery

Discharge characteristics (25°C, 77°F)

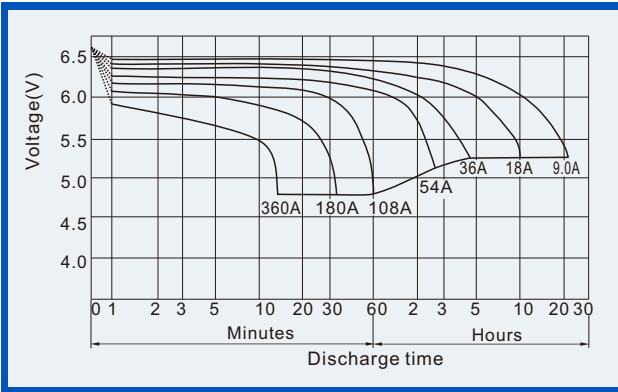

Charge characteristics (25°C, 77°F)

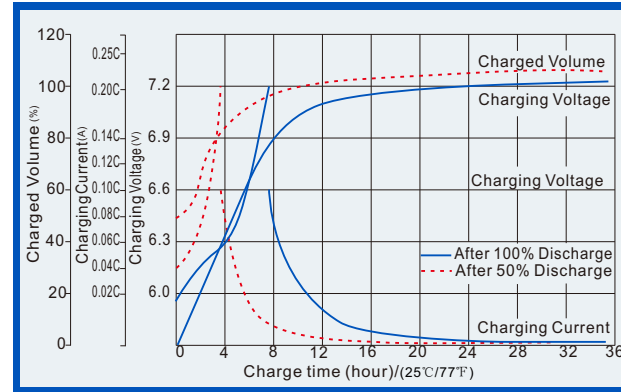

Life characteristics of Cyclic Use (25°C, 77°F)

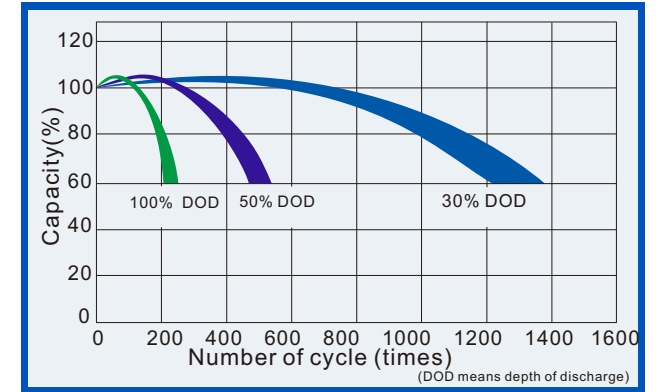

Effect of Temperature on capacity



Self-discharge characteristics



Life Characteristics of float service (25°C, 77°F)

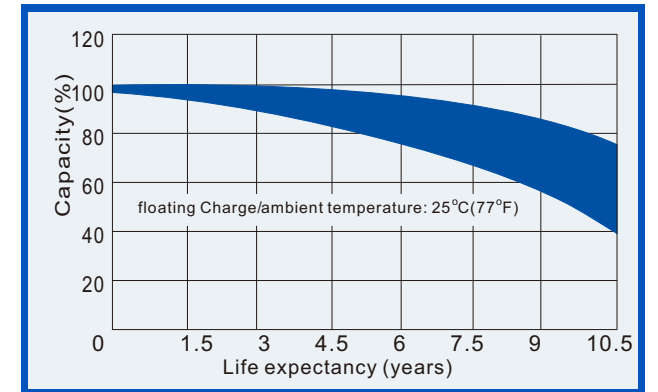

Relationships for open voltage and remained capacity (for reference)

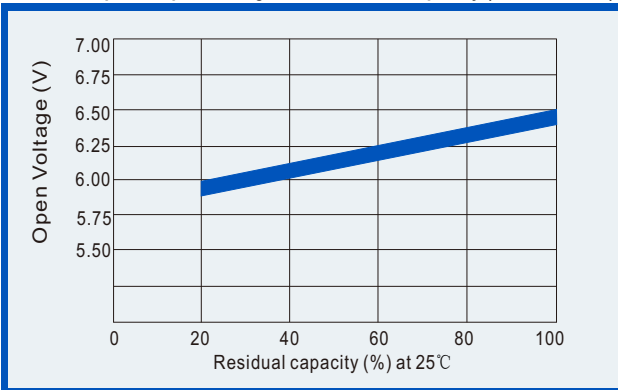

Relationship for charging voltage and temperature

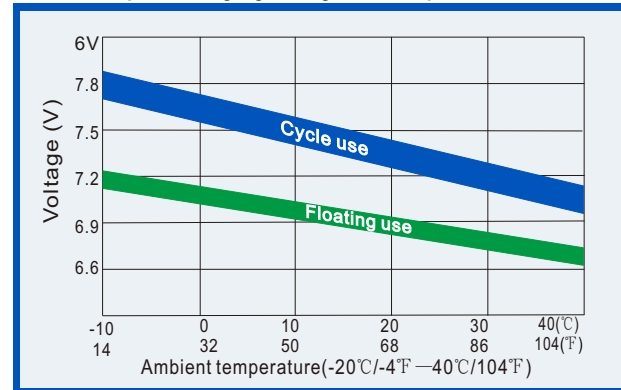

Temperature effects on floating life

