

General features for MPb Series (AGM) battery

- * Stable quality & high reliability.
- * Unique construction and sealing technique guarantees.
- * Design life 10years in float service;the battery comply to the most popular international standards,like IEC60896-21/22,etc
- * Maintenance-free operation.
- * UL-recognized component.
- * Heavy duty grids:
The heavy-duty lead calcium-alloy grids ,provide an extra margin of performance and service life in float & cyclic.
- * Case and cover are available in both standard and flame retardant ABS.
- * Low self discharge;low pressure venting system.



Maxton Power Tech Co.,Ltd
www.maxtonpower.com
info@maxtonpower.com

MP6-225 (6V225Ah)

Specifications

Nominal Voltage		6V
Rated capacity (20 hour rate)		225 Ah
Dimensions (±2mm)	Total Height	275 mm (10.83 inches)
	Height	275 mm (10.83 inches)
	Length	243mm (9.57 inches)
	Width	188mm (7.70 inches)
Weight Approx (±3%)		32.0 Kg (70.6 lbs)

Battery picture and construction



Battery Construction

Component	Positive plate	Negative plate	Container	Cover
Raw material	Lead dioxide	Lead	ABS	ABS
Component	Electrolyte	Separator	Safety valve	Terminal
Raw material	Dilute sulfuric acid	Fiberglass	Rubber	Copper

Outer dimension and terminal

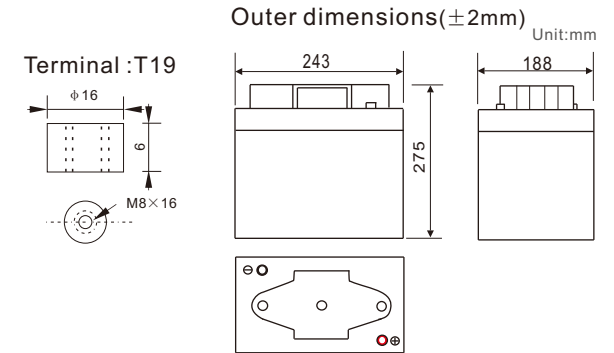

Characteristics

Capacity 25°C(77°F)	20 hour rate(11.25 A,5.25V) 10 hour rate(20.9A,5.4V) 5 hour rate(33.5A,5.25V) 1 hour rate(126 A,4.8V)	225Ah 209Ah 167.5Ah 126 Ah
Internal Resistance	Full charged battery at 25°C(77°F)	Approx 1.8 mΩ
Capacity affected by Temperature (20hour rate)	40°C (104°F) 25°C (77°F) 0°C (32°F) -15°C (5°F)	102% 100% 85% 65%
Remaining capacity Self-Discharge At 25°C(77°F)	Capacity after 3 month storage Capacity after 6 month storage Capacity after 12 month storage	91% 82% 64%
Terminal type	T19	
Max. Discharge current 25°C/(77°F)	1550A (5Seconds)	
Nominal operating temperature	25°C ±5°C(77°F ±9°F)	
Operating Temperature Range	Discharge Charge Storage	-15°C ~50°C (5°F ~122°F) -10°C ~50°C (14°F ~122°F) -20°C ~50°C (-4°F ~122°F)
Charge methods (constant Voltage) At 25°C(77°F)	Cycle use	Initial Charging Current less than 56.3A Voltage 7.25-7.45V Temperature compensation:-15mV/°C
	Standby use	Voltage 6.75-6.90V Temperature compensation:-9mV/°C

Constant current discharge (25°C , 77 °F)

Constant power discharge (25°C , 77 °F)

Unit:A

Unit:watts

Constant Current(Amp) and Constant Power(Watt) Discharge Table at 25°C(77°F)												
Time	5min	10min	15min	30min	1h	2h	3h	4h	5h	8h	10h	20h
4.80V	A	670	442	356	239	126	73.2	53.8	41.9	34.5	24.5	11.9
	W	6917	4715	3816	2565	1356	804	599	471	393	281	138
5.10V	A	649	398	335	228	118	69.9	52.3	40.8	33.9	23.9	11.5
	W	6932	4449	3751	2560	1335	806	606	474	395	279	135
5.25V	A	628	356	293	213	114	68.2	51.1	40.2	33.5	23.6	11.3
	W	6857	4054	3346	2456	1323	791	595	470	393	278	133
5.40V	A	605	336	272	197	110	66.5	49.8	39.5	32.6	23.0	11.0
	W	6790	3873	3139	2279	1286	779	587	467	386	273	131
5.55V	A	585	315	252	176	107	64.9	48.1	38.5	31.8	22.4	10.7
	W	6632	3644	2928	2057	1255	767	572	459	380	268	129

(Above characteristics data are average values obtained within three charge/discharge cycles,not the minimum values.)

VRLA Battery (AGM technology) Maintenance-free Sealed Lead Acid Rechargeable Battery

Discharge characteristics (25°C, 77°F)

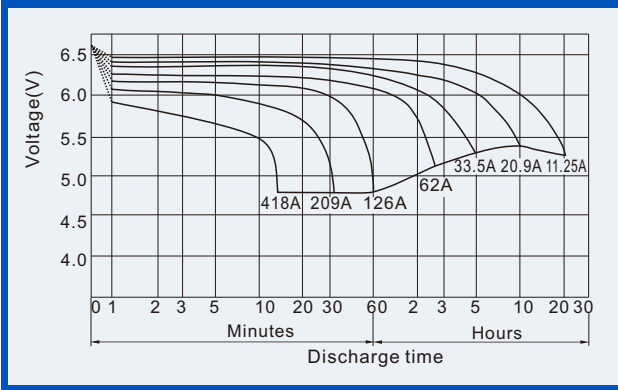

Charge characteristics (25°C, 77°F)

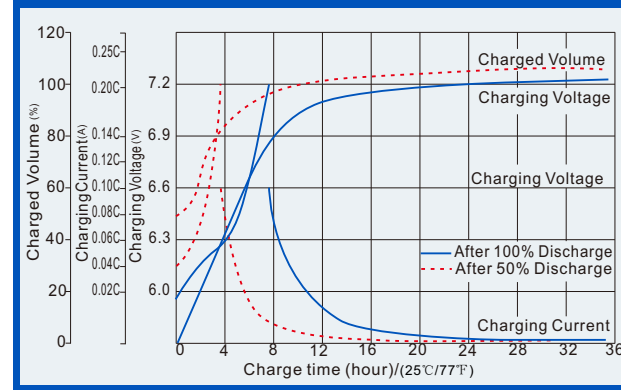

Life characteristics of Cyclic Use (25°C, 77°F)

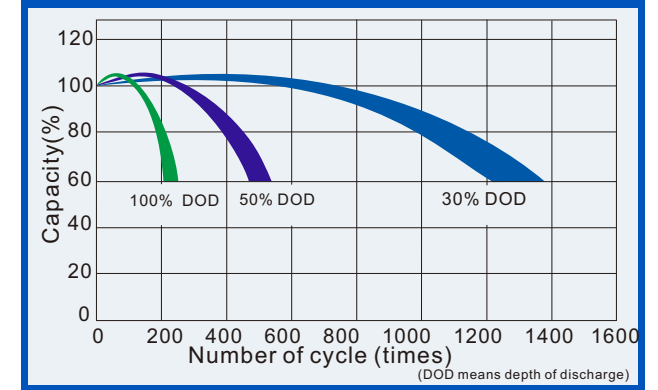

Effect of Temperature on capacity

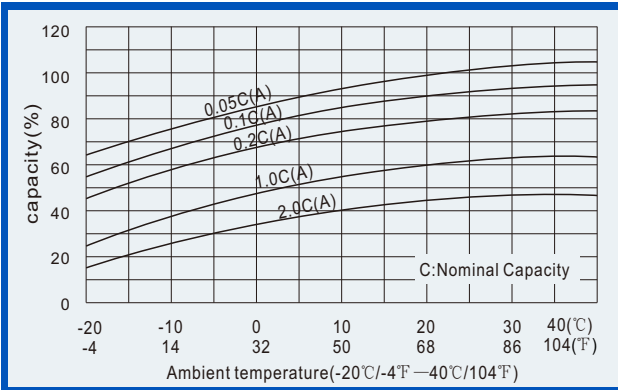

Self-discharge characteristics

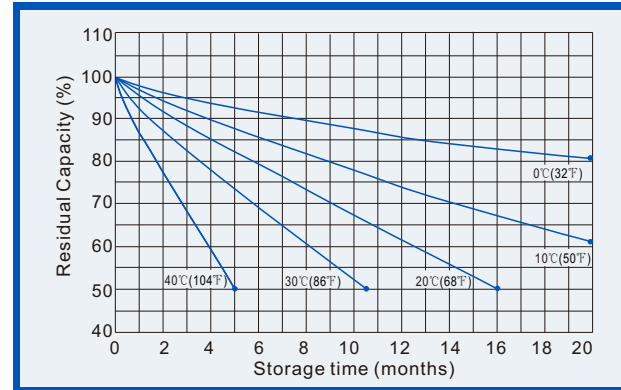

Life Characteristics of float service (25°C, 77°F)

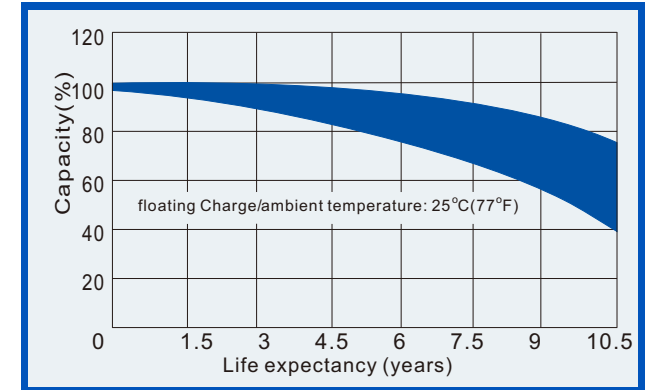

Relationships for open voltage and remained capacity (for reference)

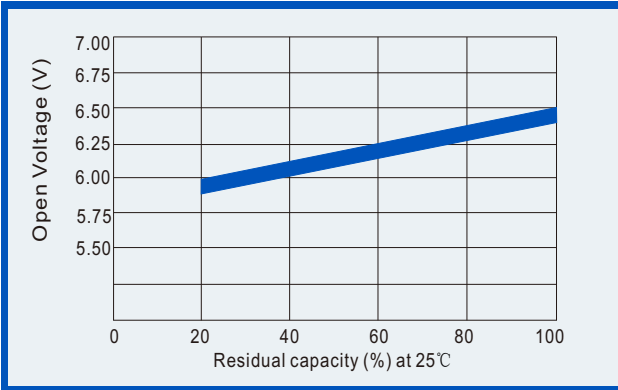

Relationship for charging voltage and temperature

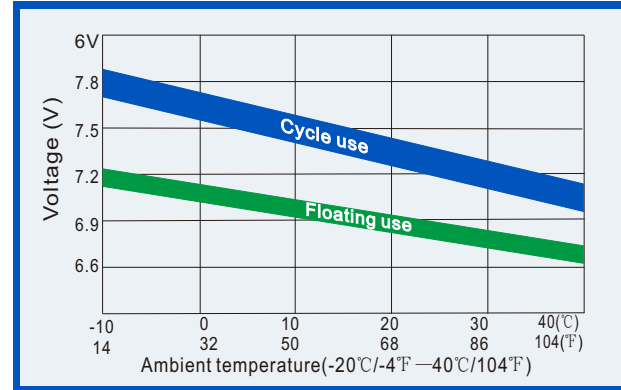

Temperature effects on floating life

