

## General features for MPb Series (AGM) battery

- \* Stable quality & high reliability.
- \* Unique construction and sealing technique guarantees.
- \* Design life 10years in float service;the battery comply to the most popular international standards,like IEC60896-21/22,etc
- \* Maintenance-free operation.
- \* UL-recognized component.
- \* Heavy duty grids:  
The heavy-duty lead calcium-alloy grids ,provide an extra margin of performance and service life in float & cyclic.
- \* Case and cover are available in both standard and flame retardant ABS.
- \* Low self discharge;low pressure venting system.



**Maxton Power Tech Co.,Ltd**  
www.maxtonpower.com  
info@maxtonpower.com

**MP6-300 (6V300Ah)**

## Specifications

Nominal Voltage		6V
Rated capacity (10 hour rate)		300 Ah
Dimensions (±2mm)	Total Height	350 mm (13.8 inches)
	Height	345 mm (13.6 inches)
	Length	295 mm (12.6 inches)
	Width	178 mm (7.00 inches)
Weight Approx (±3%)		44.5 Kg (98.1lbs)

## Battery picture and construction



### Battery Construction

Component	Positive plate	Negative plate	Container	Cover
Raw material	Lead dioxide	Lead	ABS	ABS
Component	Electrolyte	Separator	Safety valve	Terminal
Raw material	Dilute sulfuric acid	Fiberglass	Rubber	Copper

## Outer dimension and terminal

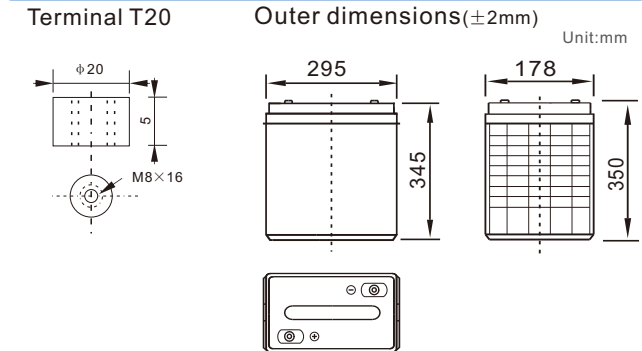

## Characteristics

Capacity 25°C(77°F)	10 hour rate(30 A,5.4V) 5 hour rate(48A,5.25V) 1 hour rate(180 A,4.8V)	300Ah 240Ah 180Ah
Internal Resistance	Full charged battery at 25°C(77°F)	Approx 1.8m $\Omega$
Capacity affected by Temperature (10hour rate)	40°C (104°F) 25°C (77°F) 0°C (32°F) -15°C (5°F)	102% 100% 85% 65%
Remaining capacity Self-Discharge At 25°C(77°F)	Capacity after 3 month storage Capacity after 6 month storage Capacity after 12 month storage	91% 82% 64%
Terminal type	T20	
Max. Discharge current 25°C/(77°F)	2325A (5Seconds)	
Nominal operating temperature	25°C ±5°C(77°F ±9°F)	
Operating Temperature Range	Discharge Charge Storage	-15°C ~50°C (5°F ~122°F) -10°C ~50°C (14°F ~122°F) -20°C ~50°C (-4°F ~122°F)
Charge methods (constant Voltage) At 25°C(77°F)	Cycle use Standby use	Initial Charging Current less than 75A Voltage 7.25-7.45V Temperature compensation:-15mV/°C Voltage 6.75-6.90V Temperature compensation:-9mV/°C

## Constant current discharge (25°C , 77 °F)

## Constant power discharge (25°C , 77 °F)

Unit:A

Unit:watts

Time	5min	10min	15min	30min	1h	2h	3h	4h	5h	8h	10h	20h
4.80V	A	962	634	511	342	180	105.1	77.2	60.1	49.6	35.1	17.0
	W	4965	3385	2739	1841	973	577	430	338	282	201	99
5.10V	A	932	572	481	327	169	100.3	75.1	58.6	48.7	34.2	16.5
	W	4948	3193	2692	1838	958	578	435	341	284	200	97
5.25V	A	901	512	421	306	164	97.9	73.3	57.7	48.1	33.9	16.2
	W	4922	2910	2401	1763	950	568	427	337	282	200	95
5.40V	A	869	482	391	282	159	95.5	71.5	56.8	46.9	33.0	15.8
	W	4874	2780	2253	1636	923	559	421	335	277	196	94
5.55V	A	840	452	361	252	153	93.1	69.1	55.3	45.7	32.1	15.3
	W	4760	2616	2101	1476	901	550	410	329	272	192	93

(Above characteristics data are average values obtained within three charge/discharge cycles,not the minimum values.)

# VRLA Battery (AGM technology) Maintenance-free Sealed Lead Acid Rechargeable Battery

**Discharge characteristics (25°C, 77°F)**

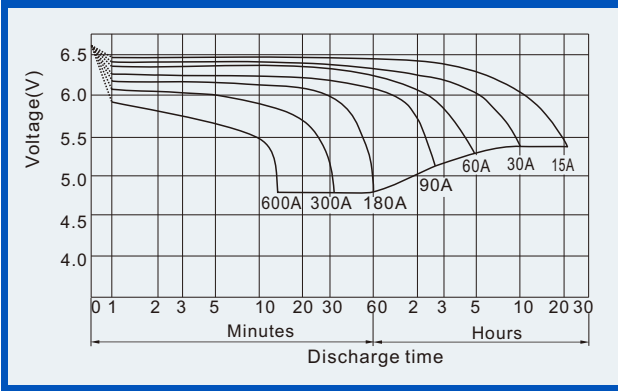

**Charge characteristics (25°C, 77°F)**

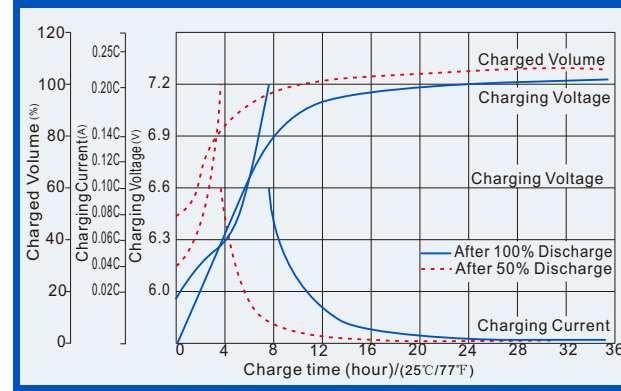

**Life characteristics of Cyclic Use (25°C, 77°F)**

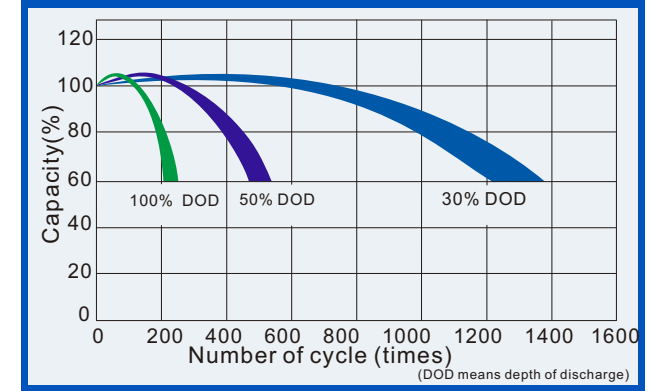

**Effect of Temperature on capacity**

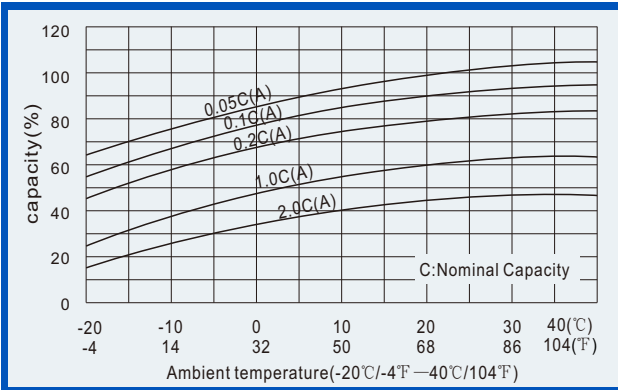

**Self-discharge characteristics**

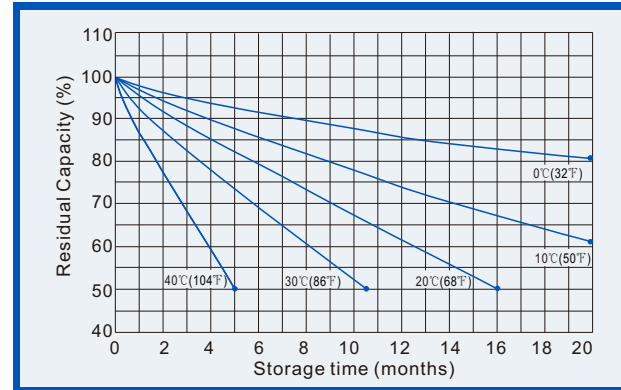

**Life Characteristics of float service (25°C, 77°F)**

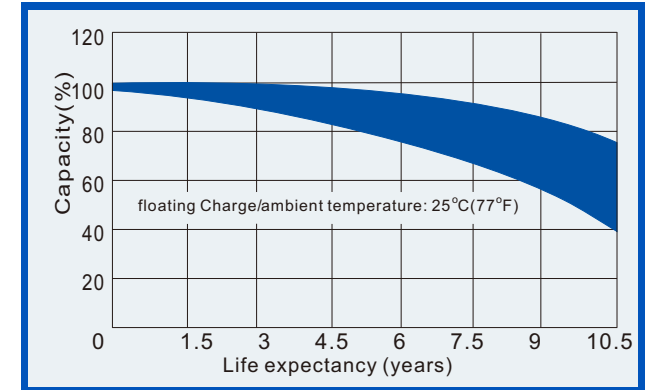

**Relationships for open voltage and remained capacity (for reference)**

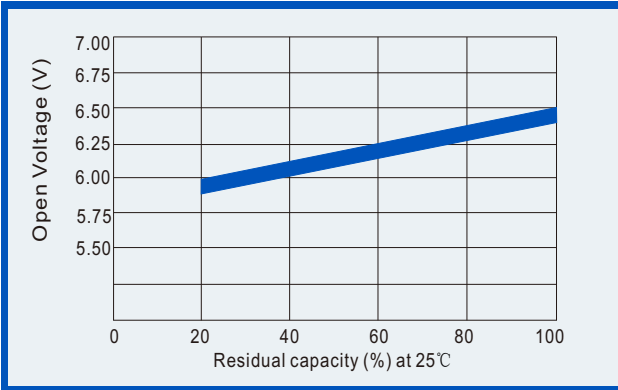

**Relationship for charging voltage and temperature**

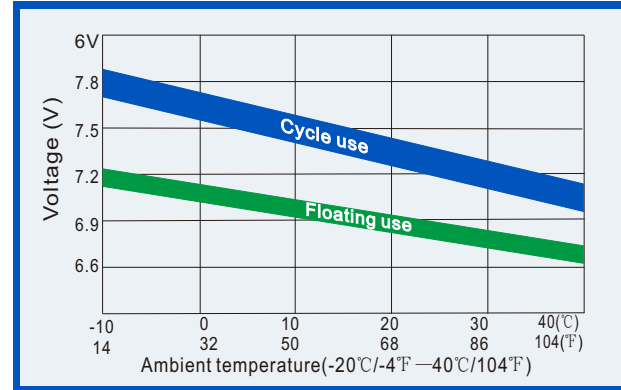

**Temperature effects on floating life**

